

IVQs in Electrical and Electronic Engineering (8030-2000)

Level 3 IVQ Technician Diploma in Electrical and Electronic Engineering
– Electrical Engineering
– Electronic Engineering
(8030-22) (500/5762/5)

Qualification handbook for centres



Publications and enquiries

City & Guilds publications are available from

Publications Sales**City & Guilds****1 Giltspur Street****London****EC1A 9DD****United Kingdom****T +44 (0)20 7294 2850****F +44 (0)20 7294 2413**

General information about City & Guilds may be obtained from Customer Relations at the above address or on +44 (0)20 7294 2787 or by emailing **intops@cityandguilds.com**.

Equal opportunities

City & Guilds fully supports the principle of equal opportunities and we are committed to satisfying this principle in all our activities and published material.

Every effort has been made to ensure that the information contained in this publication is true and correct at the time of going to press. However, City & Guilds' products and services are subject to continuous development and improvement and the right is reserved to change products and services from time to time. City & Guilds cannot accept liability for loss or damage arising from the use of information in this publication.

©2003 The City and Guilds of London Institute. All rights reserved.
City & Guilds is a trademark of the City and Guilds of London Institute.

1 Giltspur Street**London****EC1A 9DD****T +44 (0)20 7294 2468****F +44 (0)20 7294 2400****www.cityandguilds.com**

IVQs in Electrical and Electronic Engineering (8030-2000)

Level 3 IVQ Technician Diploma in Electrical and Electronic Engineering
– Electrical Engineering
– Electronic Engineering
(8030-22) (500/5762/5)

Qualification handbook for centres

Copyright

This document is copyrighted by City & Guilds (except where the copyright is acknowledged to be held by another party). Permission is given, however, for registered testing centres to reproduce pages for their own use.

[This page is intentionally blank]

Contents

05	Important notice	
06	Levels of City & Guilds qualifications	
07	IVQ in Electrical and Electronic Engineering 8030 (2000)	
07	About City & Guilds	
07	Introduction to this programme	
07	Certificate	
07	Diploma	
07	Advanced Diploma	
07	Full Technological Diploma	
07	Making entries for assessments	
07	Resources	
08	Summary of assessment	
08	Diplomas	
08	Award number	
08	Component numbers	
08	Assessments	
08	Technician Diploma in Applied Electrical Engineering	
08	Technician Diploma in Electrical Engineering Theory	
09	Technician Diploma in Applied Electronic Engineering	
09	Technician Diploma in Electronic Engineering Theory	
09	Fixed and free-date assessments	
09	Results and certification	
10	How to offer this programme	
10	Subject approval	
10	Examination centre approval	
10	Other information	
10	Designing courses of study	
10	Presentation format of units	
10	Competence statements	
10	Practical assignments	
11	Entry levels	
11	Progression routes and recognition	
11	Useful publications	
13	Syllabus	
	IVQ in Electrical and Electronic Engineering 8030 (2000)	
14	210 Engineering Fundamentals 2	
20	211 Computer Aided Communication Practical Assignments	
29	212 Electronics	
33	213 Electronics Practical Assignments	
43	214 Electrical Power	
47	215 Electrical Practical Assignments	
55	Appendix A	
	Practical assignments	
55	Practical assignments	
55	Instructor notes	
55	Candidate instructions	
55	Marking	
55	Supervision	
55	Records, results and certification	
55	Visiting verifier	
56	Model of candidate assessment record forms	

[This page is intentionally blank]

Important notice

Following the accreditation of the Technician IVQs in Electrical and Electronic Engineering (8030-2000) on the National Qualifications Framework of England, Wales and Northern Ireland (NQF), some changes have been made to the qualification, at the request of the Office of the Qualifications and Examinations Regulator (Ofqual), the qualifications regulator in England.

These changes took effect on 1 June 2009 and are outlined on this page.

Note: the content of the qualifications has not changed following accreditation.

Changes to the qualification titles

The qualification titles have changed as follows:

Technician Diploma in Applied Electrical Engineering (8030-22)
changed to

Level 3 IVQ Technician Diploma in Electrical and Electronic Engineering (Electrical Engineering) (8030-22)

Accreditation number: 500/5762/5

Technician Diploma in Applied Electronic Engineering (8030-22)
changed to

Level 3 IVQ Technician Diploma in Electrical and Electronic Engineering (Electronic Engineering) (8030-22)

Accreditation number: 500/5762/5

Changes to the unit titles

Following the accreditation of the Technician IVQs in Electrical and Electronic Engineering, each unit has been given an accreditation reference number which will appear on the Certificate of Unit Credit.

The content of the units is unchanged.

Level 3 IVQ Technician Diploma in Electrical and Electronic Engineering (Electrical Engineering) (8030-22)

Accreditation number: 500/5762/5

Y/502/2606 – Engineering Fundamentals 2

D/502/2607 – Computer Aided Communication Practical Assignments

H/502/2611 – Electrical Power

K/502/2612 – Electrical Practical Assignments

Level 3 IVQ Technician Diploma in Electrical and Electronic Engineering (Electronic Engineering) (8030-22)

Accreditation number: 500/5762/5

Y/502/2606 – Engineering Fundamentals 2

D/502/2607 – Computer Aided Communication Practical Assignments

H/502/2608 – Electronics

D/502/2610 – Electronic Practical Assignments

Registration for theory examination

Registration process for the theory examination has not changed.

Result submission for practical assessment

Result submission process for the practical assessments has not changed.

Change to the grading

The grade 'Credit' has been changed to 'Merit'. All other grades are unchanged. The content of the units concerned is also unchanged.

Notification of Candidate Results (NCR) and Certificate of Unit Credit (CUC)

Notification of Candidate Results (NCR) and Certificate of Unit Credit (CUCs) continue to be available on completion of each assessment (theory or practical).

Final certificate will be issued on successful completion of all the required assessments.

'Theory only' routes

The 'Theory only' routes continue to be available as unaccredited qualifications.

Changes to the certificate layout

Certificates issued on completion of an accredited IVQ show the accredited title and the accreditation number for the qualification. The level in the accredited title refers to the NQF level the qualification is accredited at.

The certificate also lists all the units achieved, including the grade and the unit accreditation number.

The certificate carries the logos of the regulatory authorities in England, Wales and Northern Ireland indicating that the NQF accreditation only applies to these countries.

Levels of City & Guilds qualifications

All City & Guilds qualifications are part of an integrated progressive structure of awards arranged over eight levels, allowing people to progress from foundation to the highest level of professional competence. Senior awards, at levels 4 to 7, recognise outstanding achievement in industry, commerce and the public services. They offer a progressive vocational, rather than academic, route to professional qualifications. An indication of the different levels and their significance is given below.

NQF level#	City & Guilds qualifications/programmes	Other qualifications*
8	Fellowship (FCGI)	Doctorate
7	Membership (MCGI) Master Professional Diploma Level 5 vocational awards NVQ/SVQ Level 5	Master's Degree Postgraduate Diploma Postgraduate Certificate
6	Graduateship (GCGI) Associateship (ACGI)**	Bachelor's Degree Graduate Certificate and Diploma
5	Level 5 IVQ Advanced Technician Diploma Full Technological Diploma	Higher National Diplomas Foundation Degree Diplomas of Higher and Further Education
4	Licentiate (LCGI) Higher Professional Diploma Level 4 vocational awards NVQ/SVQ Level 4	Certificate of Higher Education
3	Level 3 IVQ Advanced Diploma Level 3 IVQ Specialist Advanced Diploma*** Level 3 IVQ Technician Diploma Level 3 vocational awards NVQ/SVQ Level 3	A Level Scottish Higher Advanced National Certificate in Education BTEC National Certificate/Diploma
2	Level 2 IVQ Diploma Level 2 IVQ Specialist Diploma*** Level 2 IVQ Technician Certificate Level 2 vocational awards NVQ/SVQ Level 2	GCSE grades A*-C Scottish Intermediate 2/Credit 5 Grade BTEC First Certificate
1	Level 1 IVQ Certificate Level 1 vocational awards NVQ/SVQ Level 1	GCSE grades D-G Scottish Intermediate 1/General 5 Grade Scottish Access 1 and 2

National Qualifications Framework of England, Wales and Northern Ireland (NQF)

* Broad comparability in level

** Only graduates of the City & Guilds College, Imperial College of Science, Technology and Medicine, are awarded the Associateship (ACGI)

*** Part of a new qualification structure which is being introduced across the IVQ provision

IVQ International Vocational Qualifications

NVQ National Vocational Qualifications

IVQ in Electrical and Electronic Engineering 8030 (2000)

About City & Guilds

We provide assessment and certification services for schools and colleges, business and industry, trade associations and government agencies in more than 100 countries. We have over 120 years of experience in identifying training needs, developing assessment materials, carrying out assessments and training assessment staff. We award certificates to people who have shown they have mastered skills that are based on world-class standards set by industry. City & Guilds International provides a particular service to customers around the world who need high-quality assessments and certification.

Introduction to this programme

We have designed the Technician Diplomas in Electrical and Electronic Engineering programme for those undergoing training or employed in this area of work. The programme aims to reflect the international nature of the knowledge, skills and activities needed for different countries or cultures.

We provide certificates for all work-related areas at seven levels within our structure of awards shown in appendix B. This programme covers level 3. The standards and assessments for the certificate (level 2) and the advanced diploma (level 4) are published separately.

Certificate

The certificate (about 300 guided learning hours) provides a broad introduction to the theory and practical sides of engineering for a front-line worker or a person beginning an academic training programme.

Diploma

The diploma (about 600 guided learning hours) provides more practice involving a broader range of skills appropriate to a person who may also supervise, or who is going on into higher education.

Advanced diploma

The advanced diploma (about 600 guided learning hours) takes these skills to the level appropriate for a person preparing for or working in first level management. It is also appropriate for someone who wants to receive specialised training at a high level.

We stress that these figures are only a guideline and that we award certificates and diplomas for gaining and showing skills by whatever mode of study, and not for periods of time spent in study.

Full technological diploma

We will award the Full Technological Diploma (FTD) in Electrical and Electronic Engineering to someone who is at least 21, who has had at least two years relevant industrial experience, and who has successfully finished the assessments for the diploma and advanced diploma levels of this award. If candidates enter for this diploma, they must also send us a portfolio of evidence to support their application.

Making entries for assessments

Candidates can only be entered for the assessments in this subject if the approved examination centres agree. Candidates must enter through an examination centre we have approved to carry out the assessments for 8030 awards.

There are two ways of entering candidates for assessments.

Internal candidates

Candidates can enter for examinations if they are taking or have already finished a course at a school, college or similar training institution that has directed their preparation whether by going to a training centre, working with another institution, or by open learning methods.

External candidates

These are candidates who have not finished a programme as described above. The examination centres must receive their application for entry well before the date of the examination concerned. This allows them to act on any advice you give about assessment arrangements or any further preparation needed. External candidates carrying out practical assignments and projects, will need extra time and guidance to make sure that they meet all the requirements for this part of the assessment.

In this publication we use the term 'centre' to mean a school, college, place of work or other institution.

Resources

If you want to use this programme as the basis for a course, you must read this booklet and make sure that you have the staff and equipment to carry out all parts of the programme. If there are no facilities for realistic practical work, we strongly recommend that you develop links with local industry to provide opportunities for hands-on experience.

Summary of Assessment

There is one level of this award.

Diplomas

We use a numbering system to allow entries to be made for our awards. The numbers used for this programme are as follows.

Award number

8030-22 Technician Diploma in
Applied Electrical Engineering

Technician Diploma in
Electrical Engineering Theory

Technician Diploma in
Applied Electronic Engineering

Technician Diploma in
Electronic Engineering Theory

We use award numbers to describe the subject and level of the award.

Component numbers

210 Engineering Fundamentals 2
211 Computer Aided Communication Practical Assignments
212 Electronics
213 Electronic Practical Assignments
214 Electrical Power
215 Electrical Practical Assignments

We use component numbers to show units for which we may award a Certificate of Unit Credit.

We use these numbers throughout this booklet. You must use these numbers correctly if you send forms to us.

Assessments

Technician Diploma in Applied Electrical Engineering

To carry out what is needed for the Technician Diploma in Applied Electrical Engineering candidates must be successful in all of the following assessments.

8030-22-210 Engineering Fundamentals 2 (written paper which lasts three hours)

[8030-22-211] Computer-Aided Communication Practical Assignments

8030-22-214 Electrical Power (written paper which lasts three hours)

[8030-22-215] Electrical Practical Assignments
(Total two written papers)

The practical assignments are carried out during the learning programme and should be finished by the date of the written examination so you can send all the results to us. (See appendices A and B.)

To receive this award candidates must carry out the following practical assignments.

- 211/1, 211/2, 211/3, 215/1, 215/2 and 215/3
(Total six practical assignments)

Technician Diploma in Electrical Engineering Theory

To carry out what is needed for the Technician Diploma in Electrical Engineering Theory, candidates must be successful in all of the following assessments.

8030-22-210 Engineering Fundamentals 2 (written paper which lasts three hours)

8030-22-214 Electrical Power (written paper which lasts three hours)
(Total two written papers)

There are no practical assignments for this award.

Technician Diploma in Applied Electronic Engineering

To carry out what is needed for the Technician Diploma in Applied Electronic Engineering candidates must be successful in all of the following assessments.

8030-22-210	Engineering Fundamentals 2 (written paper which lasts three hours)
[8030-22-211]	Computer-Aided Communication Practical Assignments
8030-22-212	Electronics (written paper which lasts three hours)
[8030-22-213]	Electronic Practical Assignments (Total two written papers)

The practical assignments are carried out during the learning programme and should be finished by the date of the written examination so you can send all the results to us. (See appendices A and B.)

To receive this award candidates must complete the following practical assignments.

- 211/1, 211/2, 211/3, 213/1, 213/2 and 213/3
(Total six practical assignments)

Technician Diploma in Electronic Engineering Theory

To carry out what is needed for the Technician Diploma in Electronic Engineering Theory candidates must be successful in all of the following assessments.

8030-22-210	Engineering Fundamentals 2 (written paper which lasts three hours)
8030-22-212	Electronics (written paper which lasts three hours) (Total two written papers)

There are no practical assignments for this award.

Fixed and free dates assignments

We provide assessments in two ways.

a Fixed date

These are assessments which are carried out on dates and times we set. These assessments have no brackets around their numbers.

b Free date

These are assessments which are carried out at a college or other training establishment on a date or over a period which the college chooses. These assessments have brackets around their numbers.

In this programme the written assessments are fixed date. The practical assignments and the project are free date.

You must carry out assessments according to our International Directory of Examinations and Assessments. If there are any differences between information in this publication and the current directory, the Directory has the most up-to-date information.

Results and certification

Everyone who enters for our certificates, diplomas, and advanced diplomas receives a 'Notification of Candidate Results' giving details of how they performed.

If candidates successfully finish any assessment within this programme (for example, any one of the examination papers) they will receive a Certificate of Unit Credit towards the certificate or diploma for which they are aiming. We grade coursework assessments (practical assignments) as pass or fail. We grade written assessments on the basis of fail, pass, credit or distinction. The Certificate of Unit Credit will not mention assessments which they do not enter, which they failed or from which they were absent.

Each certificate or diploma clearly states what candidates need for full certification at the relevant level, allowing schools, colleges and employers to see whether they have met the full requirements.

If candidates successfully finish all the requirements for a full certificate or a diploma, they will automatically receive the appropriate certificate.

We will send the 'Notification of Candidate Results', Certificates of Unit Credit, certificates, diplomas and advanced diplomas to the examination centre to be awarded to successful candidates. It is your responsibility to give the candidates the certificates. If candidates have a question about the results and certificates, they must contact you. You may then contact us if necessary.

We will also send you a results list showing how all candidates performed.

How to offer this programme

To offer this programme you must get approval from us. There are two categories of approval.

Subject approval

We give approval to offer a teaching course based on this syllabus.

Examination centre approval

We give approval to enter candidates for examinations.

To be approved by us to offer a teaching course you must send us the application form.

To enter candidates for examinations you must be approved by us as an examination centre. For this programme it is possible to act as a registered examination centre only, and accept external candidates. Approved examination centres must provide suitable facilities for taking examinations, secure places to keep the examination papers and materials, and may have an appointed visiting verifier to review practical work.

After we have received and accepted an application, we will send an approval letter confirming this. You can then send entries in at any time using the International Directory of Examinations and Assessments for guidance.

Please note that in this section we have provided an overview of centre approval procedures. Please refer to the current issue of 'Delivering International Qualifications – Centre Guide' for full details of each aspect of these procedures.

Other information

Designing courses of study

Candidates for the various Technician Diplomas in Electrical and Electronic engineering will have come from different backgrounds and will have different employment and training experiences. We recommend the following:

- carry out an assessment of the candidates' achievements so you can see what learning they already have and decide the level of entry they will need; and
- consider what learning methods and places will best suit them.

When you assess a candidate's needs, you should design teaching programmes that consider:

- what, if any, previous education qualifications or training the candidate has, especially in the various general vocational education certificates we provide; and
- what, if any, previous practical experience the candidate has which is relevant to the aims of the programme and from which they may have learned the relevant skills and knowledge.

When you choose learning methods and places, you should consider the results of your assessments and whether the following are available.

- Open or distance learning material.
- Workplace learning that can be carried out on site or between you and a local workplace. This will allow the candidates access to specialised equipment and work experience.
- Working with other registered centres to share facilities.
- Opportunities for co-operative learning between candidates for different certificates who need to gain similar skills.

As long as the candidates meet the aims of this learning programme the structures of courses of study are up to you. So, it is possible to include extra topics that meet local needs.

You should avoid teaching theory alone. As far as possible the practical work should be closely related to work in the classroom so that candidates use their theory in a realistic work environment. You can use formal lectures in the classroom with appropriate exercises and demonstrations. Candidates should keep records of the practical work they do so they can refer to it at a later date.

We assume that you will include core skills, such as numeracy, communication, working with people, and organisation and planning throughout a teaching programme.

Presentation format of units

Competence statements

Most units start with a section on practical competences which shows the practical skills candidates must have.

For example:

'211.20 Present data in graphical format.

Graphical format: bar chart, pie chart, histogram, frequency polygon'

In the above statement 'Graphical format' is given as a range which the candidate should be familiar with. Candidates should cover the complete range. When a range starts with the abbreviation 'eg' the candidates only need to cover some of the ranged areas or you can use suitable alternatives.

Competence statements cover practical skills and knowledge requirements. The knowledge needed is closely linked to the practical competences, so it is best to teach the two together so that the candidate understands the topic more.

Practical assignments

You should make sure all practical assignments are supervised and instructors should make sure that the results reflect the candidate's own work. You must hold all the documents and material in a file (portfolio) for each candidate for eight weeks after the application for a certificate. You must also keep separate records of the dates of all attempts by each candidate.

Entry levels

We consider the following programmes to be relevant preparation for this programme.

Technician Certificate in Electrical and Electronic Engineering (8030)

We also consider the following Pitman Qualifications award as relevant alongside this programme.

English for Speakers of Other Languages – higher intermediate level

If candidates do not have the above qualifications, they should have secondary school leaving passes in English, mathematics and science.

Progression routes and recognition

We consider the following programmes to be relevant progression routes from this programme.

Advanced Technician Diploma in Electrical and Electronic Engineering 8030 (2000)

A number of UK universities and other higher education institutions will accept success at diploma or advanced diploma level of this programme for direct entry onto higher-level programmes. The decision to accept a candidate on to a degree programme, and the level of entry, is up to the institution. We provide details of organisations recognising achievement in this programme.

Useful publications

We can provide a list of suggested text books covering specific areas of this programme. We may also have knowledge about other support materials. You should make sure that you have the latest information. We will automatically send updated lists to centres we have approved to offer this programme.



Plain English Campaign's Crystal Mark only covers the Technician Awards in Engineering regulations.

[This page is intentionally blank]

Syllabus

IVQ in Electrical and Electronic Engineering 8030 (2000)

Component numbers and titles

210 Engineering Fundamentals 2

211 Computer Aided Communication

212 Electronics

213 Electronic Practical Assignments

214 Electrical Power

215 Electrical Practical Assignments

210 Engineering Fundamentals 2

Introduction

The aim of this unit is to further develop the concepts and skills acquired at Certificate level. It also supports a range of units at the Diploma level and serves as a pre-requisite for further studies.

Mathematics

Knowledge requirements

Instructors must ensure that candidates are able to:

Statistics

- 210.1 Collect data from practical work in other subjects and from publications.
- 210.2 Distinguish between discrete and continuous data.
- 210.3 Distinguish between a sample and a population.
- 210.4 Determine the range and approximate density of the data and use this information to form appropriate groups (equal and unequal) to cover the set of data.
- 210.5 Define frequency and relative frequency.
- 210.6 Determine, using a tally count, the frequency and hence the relative frequency of objects in each group.
- 210.7 Identify the data using either the frequencies or relative frequencies by suitable fully labelled diagrams.
Diagrams: bar charts, component bar charts, pie charts, pictograms
- 210.8 Use a labelled histogram and frequency polygon to represent a given set of data.
- 210.9 Calculate cumulative frequencies and draw an ogive.
- 210.10 Interpret descriptive data summarised in tables and in diagrams.
- 210.11 Describe the need to measure the dispersion of data.
- 210.12 Define standard deviation and variance.
- 210.13 Calculate values of standard deviation for both grouped and ungrouped data.

Logarithms

- 210.14 Define x as $\lg N$ when $N = 10^x$
- 210.15 Define x as $\ln N$ when $N = e^x$
- 210.16 Define the inverse of $a^x = y$ as $x = \log_a y$
- 210.17 Apply change of base rule where $\log_a x = \frac{\log_b x}{\log_b a}$

- 210.18 State and apply the laws of logarithms in the following forms where b is any base

Forms:

$$\log_b MN = \log_b M + \log_b N, \log_b M/N = \log_b M - \log_b N, \log_b N^a = a \log_b N$$

Algebra

- 210.19 Simplify and evaluate algebraic expressions involving negative indices.
- 210.20 Evaluate algebraic expressions involving fractional indices expressed in both numerator/denominator and decimal form.
- 210.21 Transpose formulae which contain a root or power.
- 210.22 Transpose formulae in which the subject appears in more than one term.
- 210.23 Simplify and evaluate algebraic expressions involving whole number indices.
- 210.24 Simplify and evaluate algebraic expressions involving negative number indices.
- 210.25 Solve linear equations. Solve a pair of simultaneous linear equations in two unknowns by both substitution and elimination.
- 210.26 Factorize quadratic expressions of the form of $ax^2 = bx + c$ and solve quadratic equations by factorisation and formula.

Geometry and trigonometry

- 210.27 Express angular rotations in multiples of radians. One rotation is 2π radians, n rotations is $2\pi n$ radians
- 210.28 Use the relationship $s = r\theta$ to determine the length of arc of a circle.
- 210.29 Use the relationship $A = \frac{1}{2}r^2\theta$ to determine the area of a sector of a circle.
- 210.30 Solve problems involving areas and angles measured in radians.
- 210.31 Define trigonometric functions of an acute angle.
Trigonometric functions: sine, cosine, tangent
- 210.32 Obtain values for the three trigonometric functions for angles of any magnitude from tables and from a calculator.
- 210.33 Determine an acute angle given a trigonometric function value. Angle obtained from $\sin^{-1}\theta$; $\cos^{-1}\theta$; $\tan^{-1}\theta$
- 210.34 State the relationships: $\cos\theta = \sin(90^\circ - \theta)$ and $\sin\theta = \cos(90^\circ - \theta)$ for values of θ from 0 to 90°

- 210.35 Solve problems by using trigonometric function values and/or Pythagoras' theorem.
- 210.36 Apply the sine and cosine rules to the solution of any triangle given sufficient information.
Sine Rule: $a/\sin A = b/\sin B = c/\sin C$
Cosine Rule: $a^2 = b^2 + c^2 - 2bc \cos A$
Information: one side and any 2 angles, two sides and an angle opposite to one of the given sides, two sides and the angle between them, three sides

Graphs

- 210.37 Solve graphically a pair of simultaneous equations in two unknowns.
Linear equations:
 $y = m_1x + c$
 $y = m_2x + c_2$
- 210.38 Sketch graphs of parabolas relating to quadratics.
Parabolas:
 $y = ax^2$
 $y = ax^2 + c$
 $y = (x + b)^2$
 $y = (x + b)^2 + c$
 $y = ax^2 + bx + c$
- 210.39 Approximate the gradient of a non-linear graph by defining the slope of a secant line between two points on the curve.
- 210.40 Understand the accuracy of the above approximation improves when the two points are brought closer together.
- 210.41 Approximate areas under non-linear graphs and the x-axis by splitting the region into uniform trapeziums.
Non-linear graphs: parabolas, cubics, logarithmic, sinusoidal
- 210.42 Understand the accuracy of the above approximation improves as the number of trapeziums within the defined region is increased.
- 210.43 Recognise the characteristic graphical and algebraic form of linear functions, eg $y = mx + c$
- 210.44 Sketch graphs of linear functions and identify slopes and intercepts and determine the corresponding linear laws.
- 210.45 Identify polynomial functions of order 2 or more results in a non-linear graph.
- 210.46 Sketch graphs of simple quadratic functions, identify the intercept and where appropriate the roots.
- 210.47 Identify that an odd-degree polynomial possesses at least one real root.

- 210.48 Sketch graphs of simple trigonometric functions and identify their periodic nature.
Functions: sine, cosine, tangent

- 210.49 Sketch graphs of simple exponential and logarithmic functions.

Calculus

- 210.50 Determine average and instantaneous gradients of graphs of simple functions.

Simple functions:

$$y = mx + c$$

$$y = ax^2$$

$$y = e^{kx}$$

$$y = \sin x$$

- 210.51 Deduce the chord of a graph reduces to the tangents at a point as the arc reduces to zero.

- 210.52 Identify δx and δy as incremental changes between two points on graph.

- 210.53 Define $\frac{dy}{dx}$ as the limiting value of the ratio δy when $dx \rightarrow 0$ and hence as the gradient of a graph at a particular point.

- 210.54 Determine the instantaneous gradient of simple functions using standard rules.

Standard rules:

$$\frac{d}{dx} (x^n) = nx^{n-1}, \quad \frac{d}{dx} (\sin x) = \cos x, \quad \frac{d}{dx} (e^{kx}) = ke^{kx}$$

- 210.55 Define integration as inverse of differentiation.

- 210.56 State the importance of a constant of integration.

- 210.57 Determine the indefinite integrals $\int y \, dx$ for $y = ax^n$, $y = \sin x$, $y = e^{kx}$.

- 210.58 Define $\int_a^b y \, dx$ as the area under the graph between ordinates $x = a$ and $x = b$.

- 210.59 Determine the areas under graphs of simple functions.

Science

Knowledge requirements

Instructors must ensure that candidates are able to:

Statics

- 210.60 Resolve a force into rectangular components.
- 210.61 Solve problems involving the triangle of forces theorem and application of the principle of concurrence.
- 210.62 Define a couple and describe its magnitude as a torque.
- 210.63 Use the principle of moments to calculate the support reactions of a loaded simply supported beam.
Loading: concentrated, uniformly distributed, combined

Stress and strain

- 210.64 Define stress and its unit N/m^2 or Pa
Stress: direct tensile and compression, single shear
- 210.65 Solve problems involving calculation of values of stress.
- 210.66 Define direct strain.
- 210.67 Explain Hook's law and define Young's modulus.
- 210.68 Define and explain the term factor of safety as applied to direct and shear loading.
- 210.69 Solve problems involving direct stress, strain, Young's modulus and factors of safety.
- 210.70 Explain the distinction between single and double shear.
- 210.71 Solve problems involving shear stress, ultimate shear strength and factors of safety.
Problems: rivetted and pinned joints, flanged shaft couplings, shearing and punching of flat plates

Kinematics

- 210.72 Explain why speed is a scalar quantity whereas velocity and acceleration are vector quantities.
- 210.73 Derive the equations for uniformly accelerated linear motion.
Equations:
- $$v = u + at \quad s = \frac{1}{2}(u+v)t$$
- $$s = ut + \frac{1}{2}at^2$$
- $$v^2 = u^2 + 2as$$

- 210.74 Use the equations in 210.73 to solve problems involving velocity, acceleration, deceleration and distance travelled by moving objects, eg vehicle, engineering component, freely falling body, projectile.

- 210.75 Define angular velocity, angular acceleration and their units.

Units:

$$\text{rad/s, rad/s}^2$$

- 210.76 Derive the relationships between linear and angular motion.

Relationships:

$$v = \omega.r$$

$$a = \alpha.r$$

$$s = r.\theta$$

- 210.77 Perform calculations involving the relationships in 210.76 and $\omega = 2.\pi.N$ where N is rev/s.

- 210.78 Obtain equations for uniformly accelerated angular motion by analogy with linear motion.

Equations:

$$\omega_2 = \omega_1 + \alpha.t$$

$$\theta = \frac{1}{2}(\omega_1 + \omega_2)t$$

$$\theta = \omega_1 t + \frac{1}{2}\alpha t^2$$

$$\omega_2^2 = 2.\alpha\theta$$

- 210.79 Solve problems involving angular motions using the equations in 210.78.

Dynamics

- 210.80 Explain the laws of dry friction.
- 210.81 Define the coefficient of friction.
- 210.82 Solve problems involving the force of friction and the coefficient of friction.
- 210.83 Solve problems involving the work done by a constant force.
Force: constant, inclined, uniformly varying
- 210.84 Derive the relationships for potential energy and linear kinetic energy.
Relationships:
- $$P.E. = mgh$$
- $$K.E. = \frac{1}{2}mv^2$$

- 210.85 Derive the relationships for work done (W) and power (P) transmitted by a torque (T).
Relationships:
 $W = T\theta$
 $P = T\omega$
- 210.86 Solve problems involving potential energy, kinetic energy, torque and power.
- Simple machines**
- 210.87 Explain the function of a machine and the term simple machine.
- 210.88 Define the terms velocity ratio (VR), mechanical advantage (MA) and efficiency and solve problems on a range of machines.
Machines: belt drives, gear trains, pulley blocks, screwjack, worm and wheel, winch
- 210.89 Describe the effects of friction in machines.
Effects: generation of heat, unwanted reduction in efficiency
- 210.90 Draw graphs of effort (E) against load (W) from experimental results on simple machines and obtain the law of the machine. $E = aW + b$. Show that the limiting value of efficiency is $1/aVR$.
- 210.91 Explain the term overhauling and why simple lifting machines are designed to have an efficiency of less than 50%.
- Heat**
- 210.92 Define thermal conductivity and state that thermal resistance is the reciprocal of conductance.
- 210.93 Derive an expression for the heat conducted in terms of cross sectional area (A), length (l) of the conductor, temperature difference ($T_2 - T_1$) and the coefficient of thermal conductivity (k).

$$Q = \frac{kA(T_2 - T_1)}{l}$$
- 210.94 Solve simple problems related to heat transfer by conduction.
- 210.95 Explain Boyle's law and Charles' law.
- 210.96 Combine the laws in 210.95 to give the general gas law $PV/T = a$ constant.
- 210.97 Solve problems relating to pressure, volume and temperature of gas.
- Direct current electrical circuits**
- 210.98 Explain Ohm's law and solve problems relating to voltage, current and resistance.
- 210.99 Identify from electrical circuit diagrams, series and parallel connections of resistors and in each case derive an expression for the equivalent resistance.
- 210.100 Solve problems involving series, parallel, and series-parallel circuits, limited to four resistors, and Ohm's law.
- 210.101 Define resistivity (ρ) of a conductor and the unit of resistivity and use the formula $R = \rho L/A$ to calculate the resistance of a conductor having length L and cross sectional area A .
- 210.102 Define temperature coefficient of resistance and its units, and calculate change in resistance due to a change in temperature.
- 210.103 State the formulae for power in an electrical circuit.
Formulae:
 $P = VI$
 $P = I^2 R$
 $P = V^2/R$
- 210.104 Identify the heating effect of an electrical current, Electrical energy = Power x time, and state the units joules (watt-seconds) or the kWh (kilo-watt hour).
- 210.105 Solve problems relating to 210.103 and 210.104, involving calculations of power and energy in electrical circuits.
- 210.106 Identify the uses of cells and batteries, including primary, secondary, lead acid, nickel-iron and cadmium.
Uses: primary cells in portable equipment, secondary cells in rechargeable appliances and vehicles
- Alternating current theory**
- 210.107 Explain the term 'single phase alternating current' and sketch a graph of a periodic wave.
- 210.108 Define the terms associated with alternating current.
Terms: cycle, frequency, period, peak value, instantaneous value, average value and root mean square (rms) value
- 210.109 Solve problems involving conversion of voltage and current, peak average and rms values.
- 210.110 Define resistance, inductive reactance and capacitive reactance in ac circuits.
- 210.111 Deduce the relationships between ac voltage and current when a constant voltage is applied to pure components.
Components: resistance, inductance, capacitance
- 210.112 For each case in 210.111, sketch graphs of current and voltage against time and the corresponding phasor diagrams.

210.113 Draw to scale phasor diagrams representing alternating currents and voltages in a series circuit containing capacitance and resistance and inductance and resistance.

210.114 State that the power factor of the circuits in 210.113 is $\cos \phi$ where ϕ is the phase angle between the supply current and the voltage.

210.115 State that the true power in an ac circuit is given by $VI \cos \phi$, where $\cos \phi$, is the power factor.

210.116 Solve simple problems involving the calculation of power in ac circuits.

210.117 Explain the principle of operation of an ideal transformer and use the relationship

$$\frac{E_p}{E_s} = \frac{N_p}{N_s} = \frac{I_s}{I_p} \text{ to solve simple problems.}$$

Electrical machines

210.118 State the principle of electromagnetic induction and explain the operating principles of electric motors and generators.

210.119 Describe a three-phase ac supply and explain how it can generate a rotating magnetic field.

210.120 Describe the external characteristics and uses of series and shunt-wound dc motors.

210.121 Describe the external characteristics and uses of ac induction and synchronous motors.

210.122 Explain the need for specialised starter equipment and protection devices for electric motors.

Electrical measurements

210.123 Identify and describe the correct use of electrical and electronic test instruments for measuring electrical resistance, voltage, current, power and frequency.

210.124 Describe the principle of operation of a moving coil instrument and a repulsion type moving iron instrument.

210.125 State the meaning of resolution and accuracy as used to specify the performance of electrical test instruments.

210.126 Describe the causes of error which may arise from the use of electrical and electronic test instruments.

Cause of error: electrical loading, limitation of resolution and accuracy

210.127 Compare the specifications of analogue and digital instruments using manufacturers' data and calculate the accuracy which may be attributed to a variety of different electrical measurements.

Measurements: voltage, current and resistance including low and high scale values

Assessment

Test specification for written paper Engineering Fundamentals 2 (8030-22-210)

This is a written examination paper lasting three hours with ten questions. Candidates must answer **all** 10 questions.

The examination paper will cover the knowledge specifications:

Topic	Approximate % examination weighting
Mathematics	
Statistics	12
Logarithms, algebra and graphs	12
Geometry and trigonometry	8
Calculus	8
Science	
Statics, stress and strain	10
Kinematics, dynamics and simple machines	15
Heat	5
dc electrical circuits	10
ac current theory	10
Electrical machine and electrical measurements	10

211 Computer Aided Communication Practical Assignments

Introduction

The aim of this unit is to increase candidates' skills in computer technology and in particular with databases, spreadsheets and word processing packages.

Practical competences

The candidate must be able to do the following:

Database

- 211.1 Load database software from the operating system or graphical user interface (GUI).
- 211.2 Define and create a database structure to store a given set of data.
- 211.2 Enter data into a database file.
- 211.3 Save a database file to disk with an appropriate filename in a given location.
Location: eg on hard disk, on floppy disk, in sub-directories, in network user area
- 211.4 Modify a database structure.
Modify: add fields, delete fields, change data type, change field length
- 211.5 Define and execute a single condition search for values on numeric string and date logical fields using appropriate operators.
Operators: less than (<), greater than (>), equal to (=), less than or equal to (<=), greater than or equal to (>=), not equal to (<>), is the same as, is not the same as, contains the string, comes before, comes after
- 211.6 Use Boolean operators to define and execute multiple condition searches.
Boolean operators: AND, OR
- 211.7 Define and execute sort criterion for numeric, character and date fields.
- 211.8 Print out all or part of a database.
All or part: all records in record number order, all records as sorted list, records matched by single or multiple search conditions, one selected record, selected fields only
- 211.9 Exit database software.

Spreadsheet

- 211.10 Load spreadsheet software from the operating system or GUI.
- 211.11 Open a new spreadsheet.
- 211.12 Create a simple spreadsheet from instructions.

- 211.13 Set single and global column widths.
 - 211.14 Create and insert appropriate spreadsheet column and row titles.
 - 211.15 Insert and format character and numeric data.
Character format: left, centre, right justified
Numeric format: integer, decimal, scientific, percentage, currency, date
 - 211.16 Insert formulae containing cell addresses and numbers to carry out calculations.
 - 211.17 Use absolute and relative cell addresses.
 - 211.18 Replicate formulae in a row or column.
 - 211.19 Use the sum and average functions in a spreadsheet.
 - 211.20 Present data in graphical format.
Graphical format: bar chart, pie chart, histogram, frequency polygon
 - 211.21 Save a spreadsheet with an appropriate filename.
 - 211.22 Exit spreadsheet software.
- ### Word processing
- 211.23 Load word processing software from the operating system or GUI.
 - 211.24 Open a new document.
 - 211.25 Layout and enter a simple business letter following a specified house style.
 - 211.26 Edit the contents of a document.
Edit: correct errors, insert word(s), delete word(s), insert paragraph breaks, delete paragraph breaks, move a block of text, copy a block of text
 - 211.27 Improve the layout of a document.
Improve the layout: change justification (left, right, centre, fully justified), indent paragraphs, set tabs, change margins (top, bottom, left, right), change page size/orientation
 - 211.28 Improve the appearance of a document.
Improve the appearance: enhance text (bold, italic, underline), change fonts (type, size)
 - 211.29 Spell check a document.
 - 211.30 Save a document with an appropriate filename in a given location.
Location: eg floppy disk, hard disk, sub-directory, network user area
 - 211.31 Produce a printed copy of a document on headed paper.
 - 211.32 Exit word processing software.

1 Competence references

211.1 – 211.9

2 Preparation

2.1 Location of the test

The training centre or other venue where supervision and appropriate working conditions will be provided.

2.2 Requirements

A computer system running appropriate database software and printer connected to the system with paper loaded and set up ready to print.
Database software manual.
Copy of section 6.

2.3 Instructor notes

Candidates are required to produce an engineering database.

The database structure contains five fields and contains 47 records. The database table thus created will be used to produce information on particular aspects of the stored data.

3 Candidates' instructions

- 3.1 You have 3 hours to produce an engineering database which holds data on an engine driven lawnmower (see section 6).
- 3.2 Prepare the structure of the database to contain the following fields:
 - Price
 - Part no
 - No off
 - Description
 - Section
- 3.3 Ensure that each field is of suitable length and data type.
- 3.4 Enter data from section 6 into the database.
- 3.5 Obtain a print of the database table.
- 3.6 Sort the file in ascending **price** order. Print out the sorted file.
- 3.7 Ask (query) the database to produce and print out the following lists:
 - 3.7.1 all the records which are in the **engine** section
 - 3.7.2 all the parts costing \$1.00 or less
 - 3.7.3 all the records of parts priced between \$1.00 and \$2.00 inclusive
 - 3.7.4 all the records of which contain a **no off** value of 3 or 4.
- 3.8 Ensure your name is on your floppy disk and all your print-outs and hand in to the instructor.

4 Marking

- 4.1 Assignment completed in 3 hours. ()
- 4.2 Database contains correct number of fields. []
- 4.3 The structure of the database correctly produced. []
- 4.4 Data correctly input into the database. []
- 4.5 The database table printed out. []
- 4.6 File sorted in ascending order of **price**. []
- 4.7 The production of the following lists:
 - 4.7.1 all the records which are in the **engine** section ()
 - 4.7.2 all the parts costing \$1.00 or less ()
 - 4.7.3 all the records of parts priced between \$1.00 and \$2.00 inclusive ()
 - 4.7.4 all the records of which contain a **no off** value of 3 or 4. ()
- 4.8 Disk and print-outs handed in. []

5 Assignment completion

The candidate will have satisfactorily completed this assignment if successful in all items marked with a [] and at least three of the items marked with a ().

A period of at least seven days must elapse before an unsuccessful candidate may retake this assignment.

Candidate may retake this assignment or use alternative data produced by the instructor.

6 Assignment documentation

Manufacturers parts list for a petrol driven lawnmower.

Price	Part no	No off	Description	Section
2.20	363	1	Rubber Cable Clip	Handlebars
3.20	590	4	Cutterblade Bolt, Nut and Washer	Mainframe
0.50	591	2	Washer	Mainframe
1.20	1662	1	Key	Engine
3.00	2779	4	Cutterblade 'C' type	Mainframe
6.00	2811	1	Bottom Plate	Mainframe
21.50	3607	1	Mainframe Casting	Mainframe
5.60	3617	1	Quadrant and Handlebar Bracket	Handlebars
2.50	3618	1	Handle Bracket only	Handlebars
2.50	3619	2	Upper Bearing Block	Handlebars
2.50	3620	2	Lower Bearing Block	Mainframe
1.75	3622	1	Spring Handle	Handlebars
3.20	3623	1	Rear Flap	Handlebars
3.50	3624	1	Handle Grip	Handlebars
0.80	3667	2	Rivet	Handlebars
2.90	4207	1	Front Axle Plate with Nut N/S	Mainframe
2.80	4208	1	Front Axle Plate with Nut O/S	Mainframe
4.20	4209	1	Rear Axle Assembly	Mainframe
1.60	4210	2	Connecting Rod	Engine
2.20	4884	1	Spring Handle Retaining Clip	Mainframe
1.20	4912	2	Disc Spring	Mainframe
5.50	5704	1	Handlebar Lower	Handlebars
1.20	5662	2	Handlebar Clamp Screw Assembly	Handlebars
0.90	4918	2	Outer Clamp Plate	Handlebars
1.20	5186	1	Banking Plug	Mainframe
0.90	5187	2	Axle Plate Setscrew and L/nut	Mainframe
8.50	5219	4	8" x 1 $\frac{3}{4}$ " Wheel c/w Bearing	Mainframe
4.50	5220	4	Wheel Cover	Mainframe
1.00	5221	1	Bearing	Mainframe
20.00	9248	1	Engine	Engine
3.50	6253	1	Throttle control and blade	Engine
1.20	5631	1	Mounting Block	Engine
4.50	5649	1	Handlebar Upper	Handlebars
3.20	5659	1	Throttle Cable Bracket	Engine
2.10	226013	2	Knob	Engine
0.80	9070	4	UNF Setscrew $\frac{3}{4}$ " x $\frac{5}{16}$ "	Engine
0.80	9080	2	UNF Bolt $1\frac{1}{2}$ " x $\frac{5}{16}$ "	Mainframe
0.80	9086	4	UNF Bolt $1\frac{3}{4}$ " x $\frac{5}{16}$ "	Mainframe
1.00	9082	1	UNF Bolt (Full Dog Point)	Handlebars

0.90	9116	1	UNF Setscrew 1 1/4" x 3/8"	Engine
1.10	9209	11	UNF Nylock Nut 5/16"	Handlebars
1.10	9231	4	UNF Nylon Nut Thin 1/2"	Engine
0.50	9266	15	O/D Washer 5/16" x 5/8"	Mainframe
0.50	9267	3	Large O/D Washer	Engine
0.40	9273	1	S/C Spring Washer	Engine
0.90	9303	4	Split Pin 1/2" x 3/32"	Engine
0.90	9358	2	Screw M5 x 30mm	Handlebars

1 Competence references

211.10-211.22

2 Preparation

2.1 Location of the test

The training centre or other venue where supervision and appropriate working conditions will be provided.

2.2 Requirements

A computer system running appropriate spreadsheet software and printer connected to the system with paper loaded and set up ready to print.

2.3 Instructor notes

Candidates are required to produce an engineering spreadsheet that will calculate the power consumed for an electrical machine at various phase angles. The assignment covers data input, equation input, data manipulation and text and graphical output.

3 Candidates' instructions

3.1 You must produce an engineering spreadsheet which calculates the power consumed for an electrical machine at various phase angles. You have 3 hours to complete this assignment.

3.2 Enter a suitable TITLE, your NAME, COURSE and DATE at the top of your spreadsheet.

Under a sub-heading INPUT DATA enter the following data. Note the values given must be referenced as absolute cells.

I = CURRENT (amps) 5
R1 = RESISTANCE ONE (ohms) 10
R2 = RESISTANCE TWO (ohms) 5
R3 = RESISTANCE THREE (ohms) 2

3.3 Under a sub-heading OUTPUT DATA enter the column headings and values as given below:

Column Headings:

PHASE ANGLE (degrees)	PHASE ANGLE (radians)	POWER CONSUMED (watts)
-----------------------------	-----------------------------	------------------------------

Fill the first column with values ranging from 0 to 360 in increments of 10 degrees.

3.4 Enter and copy the equations given below:

Please note that PAD = PHASE ANGLE (degrees), PAR = PHASE ANGLE (radians) and P= POWER CONSUMED (watts).

Equation 1 $P = I^2 * (\sin(PAR)) * ((1/R_1) + (1/R_2) + (1/R_3))$

Equation 2 $PAR = PAD * 3.142 / 180$

3.4.1 Insert equation 2 at the top of the second column and copy the formula over the whole range (0 to 360 degrees). This activity will convert the values in degrees (in column 1) into radians (in column 2).

3.4.2 Insert equation 1 at the top of the third column and copy the equation over the whole range (0 to 360 degrees). This activity will calculate the power consumed for each incremental value of phase angle.

3.5 Format the contents of column 2 and column 3 so that the display indicates values to 3 and 1 decimal place(s) respectively.

3.6 Obtain a print of the spreadsheet.

- 3.7 Produce a graph (chart) of power consumed (watts) against phase angle (degrees), label the axes and add an appropriate title. Obtain a print of your graph (chart).
- 3.8 Change the value of current to 15 amps and observe the new values for the power consumed. Obtain a print of your results.
- 3.9 Produce a graph (chart) of the new values of power (watts) against phase angle (degrees) and label the axes and add an appropriate title. Obtain a print of your graph (chart).
- 3.10 Change the value of the resistors to $R_1 = 30$ ohms, $R_2 = 15$ ohms and $R_3 = 10$ ohms and observe the new values for the power consumed. Obtain a print of your results.
- 3.11 Produce a graph (chart) of the new values of power (watts) against phase angle (degrees) and label the axes and add an appropriate title. Obtain a print of your graph (chart).
- 3.12 Ensure your name is on your disk and all your print-outs and hand them to the instructor.

4 Marking

- 4.1 The assignment completed in 3 hours. ()
- 4.2 Headings and input data correctly entered. ()
- 4.3 Output data and column headings correctly entered. ()
- 4.4 Equations correctly entered.
 - 4.4.1 Equation 2 correctly entered and copied. []
 - 4.4.2 Equation 1 correctly entered and copied. []
- 4.5 Columns formatted correctly and values displayed to 3 and 1 decimal places respectively. ()
- 4.6 A print-out of the spreadsheet obtained. []
- 4.7 The graph (chart) constructed and a print of the graph (chart) obtained. []
- 4.8 The modified values of the power consumed due to current change produced and printed out. ()
- 4.9 The modified graph (chart) constructed and printed. ()
- 4.10 The modified values of the power consumed due to resistance changed and print-out obtained. ()
- 4.11 The modified graph (chart) constructed and printed. ()
- 4.12 The work handed in to the instructor. []

5 Assignment completion

The candidate will have satisfactorily completed this assignment if successful in all items marked with a [] and at least 6 of the items marked with a ().

1 Competence references

211.23 – 211.32

2 Preparation

2.1 Location of test

The training centre or other venue where supervision and appropriate working conditions will be provided.

2.2 Requirements

Computer system providing access to word processing software and printer.
Word processing software user manual.
Headed paper suitable for the printer.
Copy of section 6.

2.3 Instructor notes

In this assignment the dimensions (for margins, etc) are expressed in centimetres. If different units are required, the candidate's instructions must be modified accordingly. Instructions for setting tabs should be amended if necessary to match the position of the printed company address on the headed paper to be used.

3 Candidates' instructions

3.1 The time allowed for this assignment is 2 hours. In this assignment you are required to produce a business letter (see section 6) and lay it out in a suitable style.

You are advised to read all of the instructions before commencing work. Ensure that you understand all the instructions and follow them precisely. If you are in any doubt ask the instructor.

3.2 Set the following margins and justification:

3.2.1 a left margin of 3 cm. and a right margin of 2.5 cm

3.2.2 justification to full

3.2.3 set appropriate tabs to display list of printers.

3.3 Produce the letter (see section 6) in a suitable business style.

3.4 Type in today's date.

3.5 Make the heading Order Number CC145 bold.

3.6 Use the tabs to display the list of printers.

3.7 Use italics for the text taken from Printing News.

3.8 Use the spell check to check the spelling of your letter.

3.9 Save the document with a suitable filename and print it out.

3.10 Make the following changes to your letter:

3.10.1 set the justification to left aligned

3.10.2 change the font to an alternative appropriate font

3.10.3 change the font size by two points
(eg 10 point to 12 point)

3.10.4 save and reprint the letter.

3.11 Write your name on the print-outs of the letters and hand them in to your instructor.

4 Marking

- 4.1 Assignment completed in 2 hours. ()
- 4.2 Following specification met:
- 4.2.1 left and right margins set correctly []
- 4.2.2 justification set correctly []
- 4.2.3 tabs set appropriately. []
- 4.3 Business letter produced with suitable layout. []
- 4.4 Today's date entered. ()
- 4.5 Heading made bold. []
- 4.6 Printers displayed in tab format. []
- 4.7 Italics used for text taken from Printing News. []
- 4.8 Spell check carried out. []
- 4.9 File saved with a suitable filename and printed on headed paper. []
- 4.10 The following changes made to the letter:
- 4.10.1 justification left aligned []
- 4.10.2 font changed []
- 4.10.3 font size changed by 2 points []
- 4.10.4 letter saved and reprinted. []
- 4.11 Print-outs handed in. []

6 Assignment documentation

Please send the letter to:

Mr D Green, Carlton Computers plc, 14 Milton Road,
Ashford, Kent TN28 1UR

Text of letter:

Dear

Order Number CC145

With reference to your order received today, I am writing to inform you that the Printer X1 50 is not available at present. I suggest you replace the printer with one of the models listed below:

No 1233A	Printer X2 50	\$200.00
No 1334A	Printer X2 100	\$250.00
No 1335B	Printer X3 100	\$300.00

The alternative is to take up the special offer available from January 1 in Printing News which states that customers can 'return their current printer X2 50 in part exchange for the later model Printer X2 100 or the colour printer X3 100. Customers who are interested, please contact Mr Jones at Head Office on 144 0171 288 7777'.

Please contact me if you need further assistance.

Yours

(Type your own name at the bottom of the letter and sign it)

5 Assignment completion

The candidate will have satisfactorily completed this assignment if successful in all items marked with a [] .

A period of seven days must elapse before an unsuccessful candidate may retake this assignment.

Introduction

This unit aims to provide a broad coverage of both analogue and digital electronics. An approach, with worked examples and calculations where appropriate, based on hands-on practical work is recommended. Where possible, candidates should be introduced to the uses of discrete component and integrated circuits in a range of small signal and large signal practical applications.

Practical competences

The candidate must be able to do the following:

- 212.1 Design, construct and test a single stage transistor amplifier based on or incorporating either a bipolar junction transistor (BJT) or field effect transistor (FET).
Test: measure dc voltages, determine the voltage gain, frequency response and maximum signal handling capability
- 212.2 Build and test a power amplifier incorporating integrated circuits.
Test: mid band voltage gain, frequency response, measure ac power output, dc supply power, calculate conversion efficiency
- 212.3 Observe the effects of wave shaping networks on ac signals.
Signals: sine wave, square wave

Knowledge requirements

Instructors must ensure that candidates are able to:

Integrated circuits

- 212.4 Describe the construction and operation of basic analogue and digital IC circuits in both bipolar and FET forms including CMOS.
Circuits: differential pair, complementary pair, dc feedback pair, NAND/NOR logic gates
- 212.5 Identify from manufacturers' data a range of integrated circuits.
Integrated circuits: operational amplifiers, combinational sequential logic gates, regulators
- 212.6 State the scale of integration relating to integrated circuits and identify appropriate applications of each.
Scale and applications: SSI (basic logic gates), MSI (counters and shift registers), LSI (RAM and ROM), VLSI (microprocessors eg 6502, Z80), SLSI (Pentium)
- 212.7 Explain the use of active devices as current sources and sinks in integrated circuits.

Signal shaping and coupling circuits

- 212.8 Describe, with the aid of waveform sketches, the operation of capacitor resistor (CR) circuits and the effects of the time constant on both square wave and sine wave input signals.
Circuits: differentiating, integrating
- 212.9 Determine by calculation and graphically the signal attenuation, phase shift and frequency response of typical CR coupling circuits with sine wave inputs.
- 212.10 Sketch voltage waveforms to show the effect of junction diodes and voltage reference diodes (Zener), used in conjunction with suitable biasing voltages, to form shaping and clamping circuits.

Basic transistor circuits

- 212.11 Describe briefly the construction and operation of transistor bipolar junction transistors (BJT) and field effect transistors (FET).
- 212.12 Explain how the dc operating conditions of common source and common emitter amplifier circuits are established and stabilised by use of current and voltage feedback biasing.
- 212.13 Describe the operation of transistors as a switch and the limiting conditions.
Transistors: BJT, FET
Limiting conditions: saturation, cut-off
- 212.14 Describe briefly the causes of switching delays in a transistor switching circuit.
Causes: stored charge, transfer of charge
- 212.15 Calculate the dc voltage and current levels established by the use of current feedback biasing in single stage amplifier circuits.
Circuits: common emitter bipolar transistor, common source field effect transistor
- 212.16 Explain the terms 'small signal' and 'large signal' operation of a transistor.
- 212.17 Define the ac 'small signal' parameters for a bipolar transistor in common emitter configuration.
Parameters: forward current ratio (h_{fe}), input resistance (h_{ie})
- 212.18 Define the ac 'small signal' parameters for a field effect transistor in common source configuration.
Parameters: forward transfer conductance (g_{fs} or g_m), output resistance (g_{os} or $1/r_o$)
- 212.19 Calculate, using simplified ac equivalent circuits, the voltage gains of single stage amplifier circuits.
Circuits: common emitter, common source

- 212.20 Compare the performance of bipolar and field effect transistor amplifiers using the results obtained in 212.19.

Basic amplifier circuits

- 212.21 Describe the operation of a single stage transistor amplifier circuit.
Circuit: common emitter (BJT), common source (FET)
- 212.22 Explain the occurrence of signal distortion under the Class A operation.
- 212.23 Calculate the voltage and current gains of two stage amplifiers using the appropriate equivalent circuits and typical device parameters.
Amplifiers: common emitter, common source
Devices: bipolar transistor, field effect transistor
- 212.24 Sketch typical 'small' signal frequency response curves (gain in dB against logarithmic frequency) for an amplifier and state the reasons for the fall in gain at low and high frequencies.
- 212.25 Define bandwidth as the frequency band between the two frequencies where the gain of an amplifier has fallen by 3dB from its mid band value.
- 212.26 Explain briefly the various modes (classes) of operation used in amplifiers.
Modes: A, B, C, D

Feedback

- 212.27 Describe briefly, using block diagrams, the basic principles of positive and negative feedback.
- 212.28 Define feedback factor and calculate the gain of an amplifier having a negative feedback loop with a feedback factor β .
- 212.29 Explain the effects of negative feedback.
Negative feedback: reduces noise, reduces distortion, stabilizes gain, modifies bandwidth, modifies input and output impedances
- 212.30 Describe the types of negative feedback and compare their performances.
Performance: voltage gains (A_v), current gain (A_i), input impedance (Z_{in}), output impedance (Z_o)
Types: series, parallel, voltage, current
- 212.31 Describe briefly the operation of simple single stage negative feedback amplifier circuits and determine their approximate gain.
Circuits: unbypassed emitter (or source) resistor, emitter (or source follower), voltage feedback from output to input

Oscillators

- 212.32 Define oscillators as general feedback amplifiers with positive (regenerative) feedback.
- 212.33 State the conditions for sine wave oscillations to be generated.
Conditions: gain must be infinite, loop gain must be 1, must occur at a single frequency
- 212.34 Describe the operation of a 3-stage RC phase shift oscillator.
- 212.35 Describe with the aid of a circuit diagram, the operation of a single tuned-circuit oscillator.
- 212.36 Perform calculations of gain and frequency of RC and tuned-circuit oscillators.
- 212.37 State the frequency range of RC and LC oscillators.
Frequency range: RC – low frequency and audio, LC – high frequency
- 212.38 State the advantages of using crystal control in oscillators.
Advantages: preset frequencies, high stability

Operational amplifiers

- 212.39 State the characteristics of a typical operational amplifier.
Characteristics: open loop gain is high, input resistance is high, output resistance is low, gain bandwidth product is 1 MHz
- 212.40 Sketch the open loop response of a typical operational amplifier and show how this is modified by negative feedback to produce a constant gain bandwidth product.
- 212.41 Sketch the circuits and describe the operation of a range of operational amplifier circuits incorporating resistor capacitor networks.
Amplifiers: integrator, ac coupled amplifier having a high-pass frequency response, dc amplifier having a low pass frequency response
- 212.42 Calculate the mid band voltage gains and bandwidths of the high-pass and low-pass operational amplifier circuits given typical component values.
Amplifiers: ac coupled amplifier having a high-pass frequency response, dc amplifier having a low-pass frequency response

Basic logic circuits

- 212.43 Explain, using truth tables, the operation of a range of 2 input logic gates.
Logic gates: AND, OR, NAND, NOR, XOR
- 212.44 Reduce simple Boolean expressions using logical relationships.
- 212.45 Construct combinational gate systems to implement simple Boolean expressions or truth tables.

- 212.46 Explain the need for a latch.
- 212.47 Draw the circuit and explain the operation of a simple RS latch.
- 212.48 Explain with the aid of a logic diagram the operation of the cross-coupled NAND or NOR gates.

Power output circuits

- 212.49 Compare efficiencies of a range of amplifiers.
Amplifiers: Class A, Class AB, Class B
- 212.50 Describe typical applications for the range of amplifiers in 212.49 above.
- 212.51 Explain, with the aid of a diagram, the operation of a Class B push-pull amplifier (using complementary transistors).
- 212.52 State the effect of cross-over distortion and explain how it can be eliminated.
- 212.53 Explain, with the aid of a diagram, the operation of a Class AB push-pull amplifier incorporating a bootstrap capacitor.
- 212.54 Using manufacturers' data sheets, select a range of power ICs for given applications, eg LM380, TDA2030.

Use of instruments

- 212.55 Explain the functions of the main controls of an oscilloscope.
Controls: channel gain, time base speed, sync/trigger, time base mode (alternate scan or switching)
- 212.56 Describe applications of the oscilloscope.
Applications: waveform observation, measurement of amplitude, time, frequency and phase
- 212.57 Describe the use of probes to improve the performance of oscilloscopes and electronic instruments at high frequencies.
Types of probe: low capacitance, multiplier, rectifier
- 212.58 Define the terms 'resolution' and 'accuracy' of instruments and determine typical values from manufacturer's data.
- 212.59 Calculate errors in instrument readings and the tolerance which must be applied arising from practical limitations.
Limitations: loading due to instrument impedance, resolution and accuracy of the instrument
- 212.60 Describe the operation and use of a simple logic probe.

Optoelectronics

- 212.61 Explain that light energy generates electron-hole pairs in a semiconductor.
- 212.62 Describe briefly the construction and operation of a range of photo sensitive devices.
Devices: photo resistive cells (light-dependent resistors – LDR), photovoltaic cells (solar cells), photo diodes, photo transistors
- 212.63 Compare the relative merits of a range of photo sensitive devices.
Merits: cost, size, linearity, dynamic range, speed, temperature sensitive
Devices: light dependent resistors, solar cells, photo diodes and transistors
- 212.64 Describe typical applications of photo sensitive devices.
Typical applications: light operated relay, power source (solar cell), light meter, light sensitive switch
- 212.65 Describe the emission of light generated by passing current through a forward biased junction (light emitting diode – LED).
- 212.66 Determine, using manufacturers' or suppliers' information, details of commercially available light emitting diodes.
Details: emission colour, forward voltage, maximum current and power ratings, size
- 212.67 Sketch circuits for the operation of various LEDs and calculate suitable component values from the information obtained in 212.66.
- 212.68 Describe briefly the construction and operation of an opto-isolator and state typical applications.
Applications: completely isolated non-electrical coupling, switching high voltage loads from sensitive low voltage sources
- 212.69 Describe the principle of light propagation along a fibre optic cable and explain the associated terms.
Terms: step index, graded index
- 212.70 Sketch a simple block diagram and describe the operation of a fibre optic communication system.
System: transmission, receiver, fibre optic cable

Assessment

Test specification for written paper Electronics (8030-22-212)

This is a written examination paper lasting three hours with ten questions. Candidates must answer **all** questions.

The examination will cover the knowledge specifications:

Topic	Approximate % examination weighting
Integrated circuits	5
Signal shaping and coupling circuits	5
Basic transistor circuits	10
Basic amplifier circuits	15
Feedback	10
Oscillators	10
Operational amplifiers	5
Basic logic circuits	10
Power output circuits	10
Use of instruments	10
Optoelectronics	10

213 Electronics Practical Assignments

Practical assignment 213/1: Wave Shaping

1 Competence references

212.3

2 Preparation

2.1 Location of test

The training centre or other venue where supervision and appropriate working conditions will be provided.

2.2 Components: wave shaping networks as shown in section 6, figure 1a, 1b and 1c mounted on a suitable test board.

Test equipment: function generator, 2-channel oscilloscope and suitable test leads.

Support facilities: drawing and writing materials, copy of section 6.

2.3 Instructor notes

Candidates are required to connect up the networks in section 6, observe the effects of wave shaping networks on ac signals, record the results and explain the operation of the networks.

Candidates have 3 hours to complete this assignment.

Instructors must ensure that health and safety regulations are observed at all times.

3 Candidates' instructions

3.1 You have three hours to complete this assignment.

In this assignment you are required to:

- observe the effects of wave shaping networks on ac signals
- record all results
- explain the operation of the networks.

3.2 Signal connections and test procedures

3.2.1 Connect, in turn, each of the networks shown in section 6, figures 1a, 1b and 1c to a signal generator and oscilloscope as shown in figure 2.

3.2.2 For network 1a, set the function generator to give a 1kHz sinewave having an amplitude of 24V peak to peak. This waveform is monitored on channel 1 of the oscilloscope.

3.2.3 Observe the output waveform of the network on channel 2 of the oscilloscope.

3.2.4 Sketch the shape of the waveform and record the voltage levels of both the negative and positive peaks measured with respect to zero volts of dc.

3.2.5 Replace network 1a with network 1b and repeat steps 3.2.3 and 3.2.4 keeping the same input signal.

3.2.6 Replace network 1b with network 1c and change the input signal setting to a 1kHz square wave having an amplitude of 20V peak to peak. Repeat steps 3.2.3 and 3.2.4.

3.3 Conclusions

3.3.1 For the networks, explain the reasons for the shapes of the output waveforms and the associated voltage levels.

3.3.2 Write your name on your work and hand it in to your instructor.

4 Marking

- 4.1 Assignment completed in three hours. ()
- 4.2 Signal connections and test procedures
- 4.2.1 Each of the networks shown in section 6, figures 1a, 1b and 1c connected in turn to a signal generator and oscilloscope as shown in figure 2. []
- 4.2.2 For network 1a, the function generator set to give a 1kHz sinewave having an amplitude of 24V peak to peak. This waveform monitored on channel 1 of the oscilloscope. []
- 4.2.3 Observation of the output waveform of the network on channel 2 of the oscilloscope. []
- 4.2.4 The shape of the waveform sketched and the voltage levels recorded of both the negative and positive peaks measured with respect to zero volts of dc. []
- 4.2.5 Network 1a replaced with network 1b and steps 3.2.3 and 3.2.4 repeated, keeping the same input signal. []
- 4.2.6 Network 1b replaced with network 1c and the input signal setting changed to a 1kHz square wave having an amplitude of 20V peak to peak. Steps 3.2.3 and 3.2.4 repeated. []
- 4.3 Conclusions
- 4.3.1 For the networks, explanation given for the reasons for the shapes of the output waveforms and the associated voltage levels. []
- 4.3.2 Name written on work and handed in to instructor. []

5 Assignment completion

The candidate will have satisfactorily completed this assignment if successful in all the items marked with [].

A period of several days must elapse before an unsuccessful candidate may retake this assignment. An alternative circuit design should be used.

6 Assignment documentation

6.1 Wave shaping

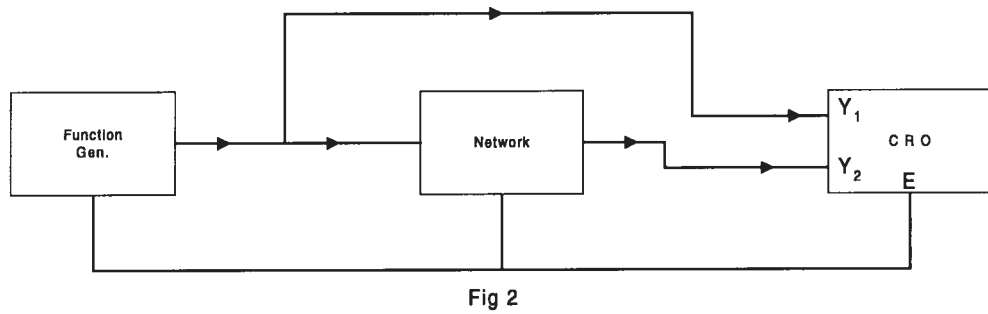
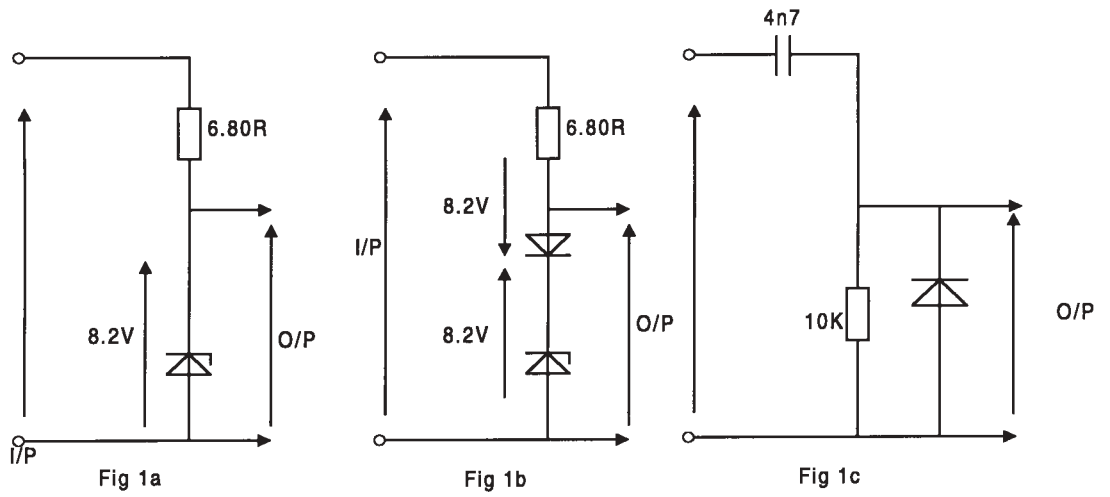

213 Electronics Practical Assignments

Practical assignment 213/2: Design and Build a Common Emitter Transistor Amplifier

1 Competence references

212.1

2 Preparation

2.1 Location of test

The training centre or other venue where supervision and appropriate working conditions will be provided.

2.2 Requirements

Components: Range of electronic components: 1 transistor, 4 resistors and 2 capacitors. Suitable circuit board, strip board or printed circuit board.

Tools: kit of small tools and soldering iron for electronic assembly. Resin-cored solder.

Test equipment: dc power supply, multimeter (analogue or digital), audio signal generator, 2-channel oscilloscope and suitable test leads.

Support facilities: graph or squared paper, drawing and writing materials. Transistor data sheet. Copy of section 6.

2.3 Instructor notes

Candidates are required to design, build and test a single stage junction transistor common emitter amplifier.

Candidates have 6 hours to complete this assignment.

Instructors must ensure that health and safety regulations are observed at all times.

3 Candidates' instructions

3.1 The time allowed for this assignment is 6 hours. You are advised to read all the instructions before commencing work. If you do not understand all the instructions then please ask your instructor.

In this assignment you are required to identify the components (see circuit diagram section 6), solder the components to the matrix board to the layout in the circuit diagram.

3.2 List the components required from the diagram (section 6).

3.3 Plan the layout on graph (squared) paper and ensure the layout is economical.

3.4 Check the layout is correct with your instructor.

3.5 Insert the components in the strip board and insert pins in appropriate holes in the board to anchor the components.

3.6 Solder the components to the pins to form the amplifier circuit shown.

3.7 Power up circuit using 9 volt power supply unit (or battery).

3.8 Check dc levels throughout circuit and record the values.

3.9 Input 1 kHz signal from signal generator and display input and output on an oscilloscope. Adjust input amplitude to avoid any distortion.

3.10 Draw the input signal and the output signal and measure the amplitudes.

3.11 Calculate the voltage gain of the amplifier from the results obtained in 3.10.

3.12 Increase the input amplitude to a maximum value without causing significant distortion and record the value.

3.13 Put your name on your work and hand it in to your instructor.

4 Marking

- | | | |
|------|--|-----|
| 4.1 | Assignment completed in 6 hours. | () |
| 4.2 | The components correctly listed. | |
| 4.3 | The layout correctly and economically planned on graph (squared) paper. | [] |
| 4.4 | The layout checked by the instructor. | [] |
| 4.5 | The components inserted in the strip board and pins inserted in appropriate holes in the board to anchor the components. | [] |
| 4.6 | The components soldered to the pins to form the amplifier circuit shown. | [] |
| 4.7 | Circuit powered up using 9 volt power supply unit (or battery). | [] |
| 4.8 | Dc levels checked throughout circuit and the values recorded. | [] |
| 4.9 | Input 1 kHz signal input from signal generator and input and output signal displayed on an oscilloscope. Input amplitude adjusted to avoid any distortion. | [] |
| 4.10 | The input signal and the output signal drawn and the amplitudes measured. | [] |
| 4.11 | The voltage gain of the amplifier calculated from the results obtained in 3.10. | [] |
| 4.12 | The input amplitude increased to a maximum value without causing significant distortion and the value recorded. | [] |
| 4.13 | Work handed in to instructor. | [] |

5 Assignment completion

The candidate will have satisfactorily completed this assignment if successful in all the items marked with [].

A period of seven days must elapse before an unsuccessful candidate may retake this assignment. An alternative circuit design should be used.

6 Assignment documentation

6.1 Common emitter transistor amplifier

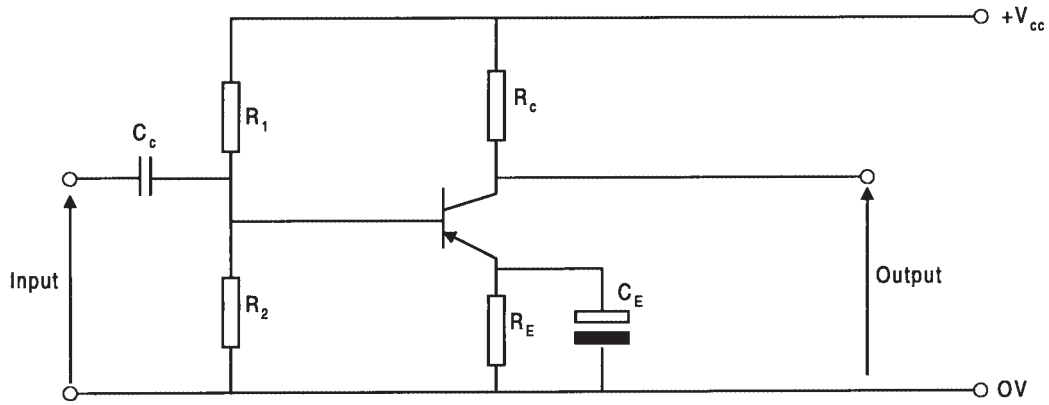

213 Electronics Practical Assignments

Practical assignment 213/3: Build and Test an Integrated Circuit Power Amplifier

1 Competence references

212.2

2 Preparation

2.1 Location of test

The training centre or other venue where supervision and appropriate working conditions will be provided.

2.2 Requirements

Components: 1 LM380 or equivalent, 2M2 logarithmic potentiometer, 2R7 resistor, 8Ω 3 watt resistor, 470μF electrolytic capacitor, 100nF capacitor, suitable circuit board with combined heat sink as advised by the manufacturers.

Tools: kit of small tools and soldering iron for electronic assembly, resin-cored solder.

Test equipment: 8Ω loudspeaker, crystal microphone, dc power supply, multimeter (analogue or digital), audio signal generator, 2-channel oscilloscope and suitable test leads.

Support facilities: drawing and writing materials, LM380 (or equivalent) data sheet, copy of section 6.

2.3 Instructor notes

Candidates are required to construct the power amplifier in section 6, ensure that the circuit functions correctly, determine the maximum signal levels, mid band gain, overall frequency response, output power and conversion efficiency using appropriate instruments. Record results and show calculations. Candidates have 3 hours to complete this assignment.

Instructors must ensure that health and safety regulations are observed at all times.

3 Candidates' instructions

3.1 You have three hours to complete this assignment. In this assignment you are required to assemble and test a single stage integrated circuit power output amplifier.

Typical Specification:

Power supply V_{CC}	20V d.c. (25V maximum)
Quiescent current	7mA
Voltage gain	50 (34dB)
Input sensitivity	150mV rms
Input resistance	150 kΩ
Maximum input voltage	0.5V
Load resistance	8Ω
Approximate bandwidth	100kHz

3.2 Sketch a circuit diagram of the proposed amplifier. See section 6, Fig 1.

3.3 Select components.

3.3.1 Choose a suitable amplifier eg LM380, or similar, and refer to the data sheet for the device to establish its specification.

3.3.2 Select the supply voltage V_{CC}

3.3.3 Select component values if different from the those shown in Fig 1.

3.3.4 Draw the circuit diagram showing the component values.

3.3.5 Draw up a component list for the proposed design.

3.3.6 Design a suitable circuit and component layout for the type of construction to be used, eg strip board or printed circuit board. Take care to include the manufacturers' recommendations for the provision of a heat sink.

3.4 Assemble the circuit using appropriate tools.

3.5 Inspect the assembled circuit and check for errors. Connect the circuit to a suitable power supply.

3.6 Carry out the following performance tests and record all results:

3.6.1 Check the supply voltage V_{CC}

3.6.2 Connect a loudspeaker across the output terminals and a crystal microphone to the input of the amplifier. Speak into the microphone and vary the setting of the volume control to test that the amplifier provides a satisfactory audio output.

- 3.6.3 Replace the microphone and loudspeaker with a signal generator and 8W resistor respectively. With the input signal frequency set to 1kHz, at a level sufficient to provide a significant output, free from any obvious distortion, measure the input and output voltages using the oscilloscope. Calculate the overall mid band voltage gain.
- 3.6.4 With the connections as in 3.6.3, increase the input voltage to determine the maximum available undistorted output voltage and record the amplitude of the input signal required to achieve this. Calculate from the amplitude of the output voltage, the ac output power delivered to the 8W load.
- 3.6.5 Under conditions of maximum ac output power, measure the dc current taken from the power supply and calculate (a) the dc power supplied to the amplifier and (b) the conversion efficiency of the amplifier.
- 3.6.6 Reset the conditions as at 3.6.3, vary the input signal over a range of frequency and monitor the change in the amplitude of the output voltage on the oscilloscope to determine the bandwidth of the amplifier.
- 3.7 Write a test report to include design calculations, results obtained from the practical measurements and any observations.
- 3.8 Hand in your work to your instructor.

4 Marking

- 4.1 Assignment completed in three hours. ()
- 4.2 A circuit diagram of the proposed amplifier sketched. ()
- 4.3 Components :
- 4.3.1 A suitable amplifier selected []
- 4.3.2 The supply voltage V_{CC} selected []
- 4.3.3 Component values if different from the those shown in Fig 1 selected []
- 4.3.4 Circuit diagram showing the component values drawn []
- 4.3.5 A component list for the proposed design drawn up []
- 4.3.6 A suitable circuit and component layout for the type of construction to be used designed []
- 4.4 The circuit assembled using appropriate tools. []
- 4.5 The assembled circuit inspected and checked for errors. The circuit connected to a suitable power supply. []
- 4.6 The following performance tests carried out and results recorded:
- 4.6.1 The supply voltage V_{CC} checked []
- 4.6.2 A loudspeaker connected across the output terminals and a crystal microphone to the input of the amplifier. ()
- 4.6.3 The microphone and loudspeaker replaced with a signal generator and 8W resistor respectively. With the input signal frequency set to 1kHz, the input and output voltages measured using the oscilloscope. The overall mid band voltage gain calculated. []
- 4.6.4 With the connections as in 4.6.3, the input voltage increased to determine the maximum available undistorted output voltage and the amplitude of the input signal required to achieve this recorded.
From the amplitude of the output voltage, the ac output power delivered to the 8W load calculated. []

- 4.6.5 Under conditions of maximum ac output power, measure the dc current taken from the power supply measured and (a) the dc power supplied to the amplifier and (b) the conversion efficiency of the amplifier calculated. []
- 4.6.6 The conditions as at 4.6.3 reset, the input signal over a range of frequency varied and the change in the amplitude of the output voltage on the oscilloscope to determine the bandwidth of the amplifier monitored. []
- 4.7 A test report written. []
- 4.8 Work handed in to the instructor. []

5 Assignment completion

The candidate will have satisfactorily completed this assignment if successful in all the items marked with [] .

A period of several days must elapse before an unsuccessful candidate may retake this assignment.

6 Assignment documentation

6.1 Integrated circuit power amplifier

Fig 1

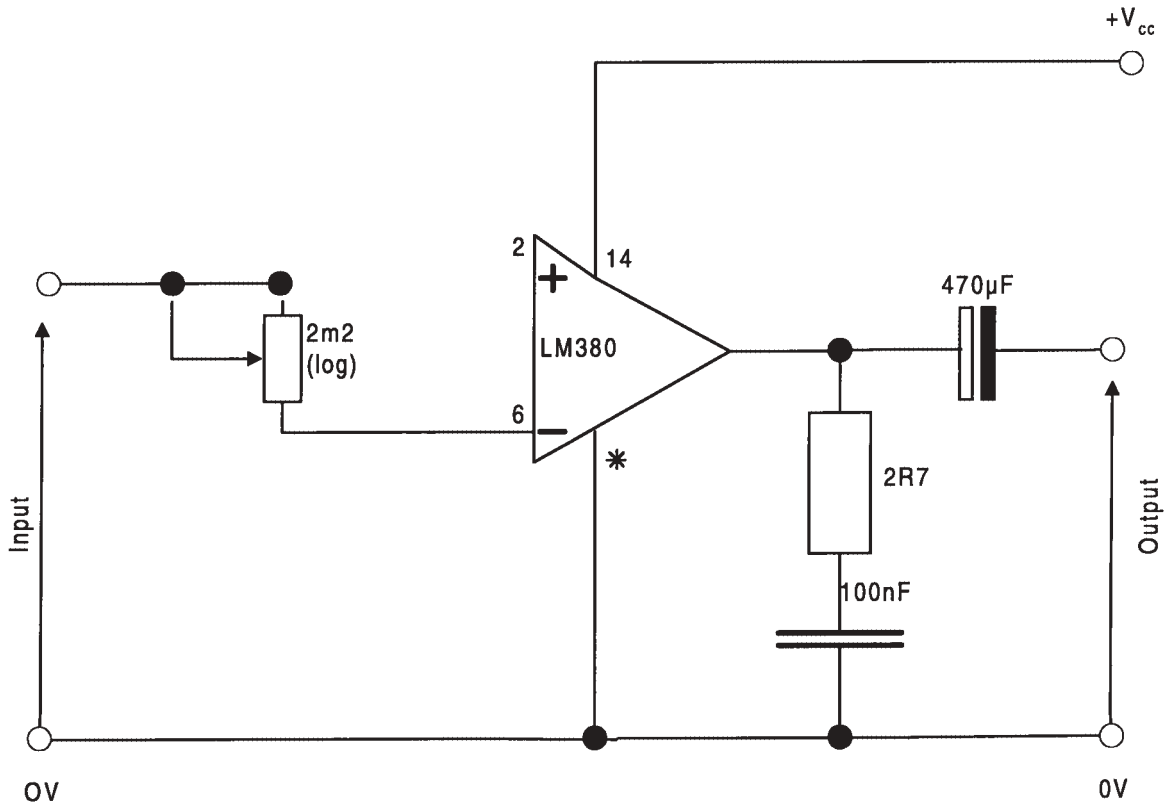

214 Electrical Power

Introduction

This syllabus extends the range of fundamental power topics and consolidates previous work on the fundamentals of dc machines, ac machines and transformers. It also covers the principles of measurements and the distribution of electrical energy.

Practical competences

The candidates must be able to do the following:

- 214.1 Carry out and record earth electrode and soil resistivity tests.
- 214.2 Investigate and record a metering installation for small industrial/commercial premises.
- 214.3 Investigate and record the basic layout of the system and types of equipment used in industrial/commercial distribution systems.

Knowledge requirements

Instructors must ensure that candidates are able to:

Testing and Measurement

- 214.4 Show with the aid of a labelled circuit diagram how a dynamometer wattmeter is connected in circuit.
- 214.5 Show with the aid of a labelled circuit diagram how a single wattmeter may be used to measure the power per phase in ac loads.
Loads: balanced, three-phase, star-connected, delta-connected
- 214.6 Show with the aid of a labelled circuit diagram how two-wattmeters may be used to measure the total power in a three-phase, three-wire load.
- 214.7 Calculate the total power measured by the two-wattmeter method from the algebraic sum of the wattmeter readings (P_1 and P_2).
- 214.8 Determine the phase angle of a balanced three-phase load by the two-wattmeter method
using the expression $\tan \phi = \sqrt{3} \left(\frac{P_2 - P_1}{P_2 + P_1} \right)$
- 214.9 Explain, with the aid of a diagram, how power and power factor may be measured in a single-phase circuit, using a voltmeter, an ammeter and a wattmeter.
- 214.10 Explain, with the aid of a diagram, how the range of instruments may be extended by the use of current and voltage transformers.

- 214.11 Solve problems in power measurement including errors inherent in the method of connecting the wattmeter.
- 214.12 Explain the use for specialised instruments when testing electrical installations and state typical acceptable values.
Instruments (testing): continuity and insulation resistance, earth fault loop and residual current device (RCD) tester.
- 214.13 Describe how earth electrode resistance may be measured.
- 214.14 Sketch a diagram of the complete earth-loop path and explain the meaning of earth fault loop impedance.
- 214.15 Explain, with the aid of a diagram how the earth-loop impedance is measured.
- 214.16 Explain typical metering requirements for a small industrial installation.
Requirements: energy, maximum demand, kVA, power factor
- 214.17 Describe, with the aid of a diagram, how meters are connected to meet the requirements in 214.16

Transmission and Distribution

- 214.18 State the advantages and disadvantages of alternating current for the generation, transmission and distribution of electrical energy.
- 214.19 Sketch a single-line diagram of a typical three-phase supply system from generator to consumer terminals.
- 214.20 State the advantages and disadvantages of various distribution systems.
Systems: radial, closed ring, open ring
- 214.21 Explain why transformers are used in transmission and distribution systems.
- 214.22 Describe, with the aid of diagrams, the difference in use between three-wire and four-wire three-phase systems.
- 214.23 Describe, with the aid of diagrams, the principles and methods of earthing of supply systems.
Systems: TN, TN-C, TN-S, TN-C-S, TT, IT
- 214.24 Describe, with the aid of a diagram, a small industrial/commercial distribution system.
- 214.25 Describe factors influencing the choice of cable for particular applications.
Factors: installation, environmental
- 214.26 State advantages and disadvantages of materials commonly used for cable conductors, insulation and sheathing.

- 214.27 Define the term 'dielectric stress'.
- 214.28 Describe methods of stress control in high voltage cables and cable terminations.
Methods: grading, intersheathing
- 214.29 Describe the function of types of switchgear used in distribution systems.
Types of switchgear: circuit breaker, disconnector (isolator), oil switch, switch fuse
- 214.30 Describe the basic methods of arc control in circuit breakers.
Methods: oil, air vacuum
- 214.31 Describe the advantages and disadvantages of fuses for system protection.
- 214.32 Define the term 'fusing factor'.
- 214.33 State the advantages and disadvantages of relays for system protection.
- 214.34 Describe the principle of operation of an inverse definite minimum time (IDMT) protection relay.
- 214.35 Describe a simple over current and earth fault protection system for a circuit.
- Power Factor Improvement**
- 214.36 Explain the disadvantages of low power factor both from the consumer and the supplier's point of view.
- 214.37 Describe methods of power factor improvement for individual loads and for overall systems.
Methods: static capacitor, synchronous machine
- 214.38 Calculate kVAr ratings and capacitance of capacitors needed to improve lagging power factor.
- 214.39 Describe typical tariff structures for individual consumers.
- 214.40 Calculate from given tariff structures the cost benefit of power factor improvement.
- DC Machines**
- 214.41 Describe, with the aid of diagrams, the principles of operation of a dc machine both in the generator and motor mode.
- 214.42 Derive the e.m.f. equation for a dc machine $E = kN\phi$.
- 214.43 Sketch circuit diagrams for field connections of dc machines.
Connections: separately excited shunt, series, compound-wound machines
- 214.44 Derive the voltage equation $V = E \pm I_a R_a$ for each connection and each mode of operation.
Mode: generator, motor
- 214.45 Derive the speed and torque equations for a dc machine in the form $T = k\phi I_a$ and $N = \frac{E}{k\phi}$.
- 214.46 Use voltage, speed and torque equations to obtain the terminal voltage/load characteristic for each type of dc generator.
Generators: shunt, series, compound, separately excited
- 214.47 Use the voltage speed and torque equations to obtain the speed/load torque characteristic for each type of dc motor.
Types of motor: separately excited, shunt, series and compound
- 214.48 Describe the process of self-excitation for a dc machine operating as a generator.
- 214.49 Determine graphically the terminal voltage of a dc shunt generator from an excitation characteristic and a field resistance line.
- 214.50 Define the term 'critical field resistance'.
- 214.51 Describe the various forms of loss occurring in a dc machine.
Forms of loss: armature, field, winding
- 214.52 Solve problems on dc motors and generators.
- 214.53 Describe methods of varying output voltage of dc generators.
- 214.54 Describe methods of varying the speed of dc motors and explain their limitations.
- 214.55 Solve problems associated with varying output voltage and speed of dc machines.
- 214.56 Explain the need for motor starters.
- 214.57 Explain, with the aid of diagrams, armature reaction and commutation in dc machines.
- 214.58 Describe methods used to overcome the effect of armature reaction on commutation.
Methods: use of interpoles, moving brush gear
- AC Machines**
- 214.59 Explain the production of a rotating magnetic field when a suitable three-phase supply is connected to the stator winding of a three-phase machine.

- 214.60 Describe with the aid of sketches, the construction of a three-phase cage- and wound-rotor induction machine.
- 214.61 Describe, with the aid of diagrams, the principle of operation of a three-phase induction motor.
- 214.62 Define and calculate values of synchronous speed, slip and slip speed.
- 214.63 Sketch the torque/speed characteristic for a typical three-phase cage-rotor induction motor, showing starting torque, maximum torque and rated torque.
- 214.64 Explain the conditions for maximum torque in an induction motor.
- 214.65 State that the starting current is 5 to 7 times the full load value for a typical three-phase cage rotor induction motor.
- 214.66 Explain the reason for connecting resistance in the rotor circuit when starting wound rotor induction motors.
- 214.67 Sketch a family of torque/speed characteristics showing the effect of varying the total rotor circuit resistance.
- 214.68 Solve problems concerning stator and rotor losses and efficiency for induction motors.
- 214.69 Describe, with a circuit diagram, a basic direct-on-line starter with no volt release provision and overload protection for a three-phase induction motor.
- 214.70 Explain why reduced voltage is used for starting large induction motors.
- 214.71 Describe methods of starting three-phase induction motors.
Methods: star-delta, autotransformer
- 214.72 Describe, with the aid of a sketch, the construction of a three-phase synchronous machine with a range of rotors.
Rotors: salient pole, cylindrical
- 214.73 Describe, with the aid of sketches, the principal modes of operation of synchronous three-phase machines.
Modes: generator, motor
- 214.74 Explain why a synchronous motor is not self starting.
- 214.75 Describe typical applications for cylindrical rotor and salient-pole rotor synchronous generators and motors.
- 214.76 Describe, with the aid of a sketch, the construction of a single-phase cage rotor induction motor.
- 214.77 State that a single-phase cage rotor induction motor is not self starting but if rotated in either direction will accelerate to load speed.
- 214.78 Describe the principle of operation of the split-phase single-phase induction motor.
- 214.79 Sketch the torque/speed characteristic for a typical split-phase, single-phase induction motor.
- Transformers**
- 214.80 Describe with the aid of sketches the construction of a typical transformer and the types of winding.
Construction: core, shell
Winding: disc, helical, layer, sandwich
- 214.81 Show that, for an ideal transformer $\frac{E_p}{E_s} = \frac{N_p}{N_s} = \frac{I_s}{I_p}$
- 214.82 Sketch and explain the no-load phasor diagram of a transformer.
- 214.83 Sketch a phasor diagram for given values of no-load (primary) current and power factor, and secondary current and power factor.
- 214.84 Calculate primary current and power factor from given data.
- 214.85 Sketch and explain the transformer equivalent circuit for load conditions.
- 214.86 State the losses for no-load and load conditions.
- 214.87 Explain the reasons for laminating the core of a transformer.
- 214.88 Describe open-circuit and short-circuit tests and their use in determining losses and efficiency.
- 214.89 Solve problems for transformers involving losses and efficiency using open-circuit and short circuit test data.
- 214.90 Define 'voltage regulation'.
- 214.91 Calculate voltage drop and regulation for various loads at lagging power factors.
- 214.92 Describe how a transformer winding can be 'tapped' to provide various voltage outputs.
- 214.93 Describe, with the aid of diagrams, the principle of operation of an autotransformer.
- 214.94 Describe suitable uses for an autotransformer.
- 214.95 Describe the advantages and disadvantages of autotransformers in relation to double wound transformers.

Assessment

Test specification for written papers Electrical Power (8030-22-214)

This is a written examination paper lasting three hours with ten questions. Candidates must answer **all** questions.

The examination will cover the knowledge specifications:

Topic	Approximate % examination weighting
Testing and measurement	14
Transmission and distribution	20
Power factor improvement	8
DC Machines	20
AC Machines	20
Transformers	18

215 Electrical Practical Assignments

Practical assignments 215/1: Earth Electrode and Soil Resistivity Tests

1 Competence references

214.1

2 Preparation

2.1 Location of tests

The training centre or other venue where supervision and appropriate outdoor work area will be provided

2.2 Requirements

1 Earth tester (megger or equivalent)
4 Earth rods (or steel rods) approximately 1.2 metres long and 16 mm diameter
4 Steel rods 0.5m long and 10mm diameter
1 Set of connecting leads and clamps
1 1 kg or 2 kg hammer
Pens, pencils, paper and graph paper

2.3 Instructor notes

Candidates may undertake the work in pairs, provided results and analysis is carried out independently.
Candidates have 3 hours to complete this assignment.

2.4 Instructor instructions

The proposed outdoor work site should be checked to ensure that there are no buried services which could be damaged.

It may be useful for the instructor to demonstrate each procedure before allowing candidates to proceed.

3 Candidates' instructions

3.1 The time allowed for this assignment is 3 hours. You are required to carry out and record earth electrode and soil resistivity tests, plot graphs obtained from these tests and describe/explain aspects of these tests. You are advised to read all the instructions before commencing work. If you do not understand all the instructions then please ask your instructor.

3.2 Earth electrode tests

Read the manufacturer's instructions for the Earth Tester to establish connections. A typical connection diagram is shown below:

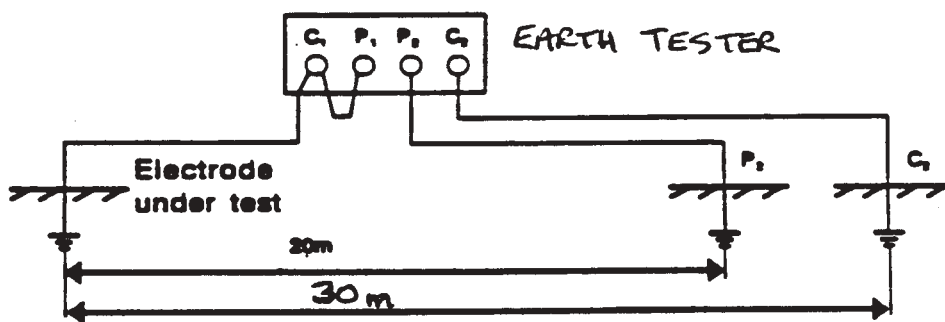

Drive one earth rod 0.3 metre into the ground, to be used as the test electrode. Using two 0.5m steel rods, place one at 20m and one at 30m from the test electrode. Drive each steel rod 0.3m into the ground. Connect the terminals on the earth tester to the earth electrode and steel rods using connecting leads and clamps. Ensure that all connections are clean and tight.

3.2.1 Use the earth tester to obtain the earth resistance of the electrode. Record the value.

3.2.2 Repeat the test with the test electrode driven in 0.4m, 0.5m, 0.6m and 0.8m into the ground.

3.2.3 Drive a second earth rod 0.8m into the ground, 1.5m from the first test electrode. Connect the two rods together using connecting wire and clamps. Test the new installation and record the value of earth resistance obtained.

3.2.4 Repeat earth tests similar to (3.4) using three and then four earth rods.

3.3 Plot a graph of the results obtained in tests 3.2 - 3.3.

3.4 Describe how the earth electrode resistance varies with the depth of the electrode.

3.5 Plot a graph of the results obtained for 1, 2, 3 and 4 electrodes each driven 0.8m into the ground.

3.6 Describe how the earth electrode resistance varies with the number of earth rods connected in parallel.

3.10 Describe TWO other methods of earthing other than using several earthing rods in parallel.

3.7 Soil resistivity

3.11 Ensure that you hand in all your work (records, graphs etc) in to your instructor.

Read the instructions for the Earth Tester being used to ascertain connections. A typical circuit for the test is shown below:

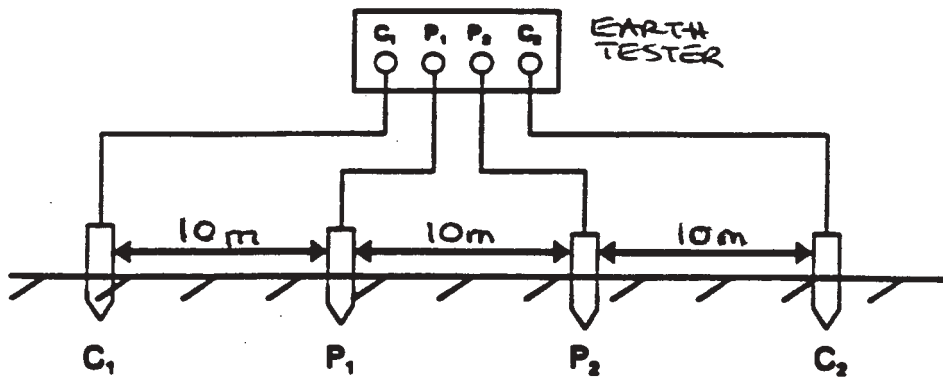

3.7.1 Drive four 0.5m steel rods 0.3m into the ground in a straight line, spaced at 10m intervals. Connect the leads to the rods using clamps, ensuring all connections are clean and tight. Use the earth tester to obtain the value of earth resistance. Record the results.

3.7.2 Drive the rods 0.4m into the ground and repeat the test. Repeat the test at a different location where the ground is either wetter or drier.

3.8.1 Calculate the value of soil resistivity for each test using the formula:

Resistivity = $2\pi a R$ ohm-cm, where a = spacing between steel rods in cms and R = earth resistance in ohms

3.8.2 Using the value of soil resistivity obtained, calculate the theoretical earth electrode resistance for a single electrode using the formula:

$$\text{Resistance} = \frac{\text{Resistivity (ohm-cm)}}{250 \times l} \times \frac{\text{Log}_{10}(4000 \times l)}{d}$$

where l is the length of the earth rod in the ground in metres and d is the diameter of the earth rod in mm.

Compare this with the value obtained in the above practical tests.

3.9 Explain why soil resistivity may vary and how this would affect the site chosen for an earth electrode installation.

4 Marking

- 4.1 Assignment completed in 3 hours. ()
- 4.2 Earth resistance tests carried out correctly. []
- 4.3 Graph of results for tests 3.2.2 and 3.2.3 plotted correctly. ()
- 4.4 Description of how earth resistance varies with depth of electrode given. ()
- 4.5 Graph of results for 1, 2, 3 and 4 electrodes plotted correctly. ()
- 4.6 Description of how earth resistance varies with the number of earth rods in parallel given. ()
- 4.7 Soil resistivity tests carried out correctly. []
- 4.8.1 Soil resistivity values calculated for each test. []
- 4.8.2 Theoretical value of earth electrode resistance calculated and compared with value from practical test. []
- 4.9 Explanation of why soil resistivity may vary and its effect on the choice of earthing site given. []
- 4.10 Descriptions of other methods of earthing given. []
- 4.11 Work handed in to the instructor. []

5 Assignment completion

The candidate will have satisfactorily completed this assignment if successful in all items marked with a [] and at least 2 of the items marked with a ().

A period of seven days must elapse before an unsuccessful candidate may retake this assignment.

215 Electrical Practical Assignments

Practical assignments 215/2: Metering Installations for Small Industrial/ Commercial Premises

1 Competence references

214.2

2 Preparation

2.1 Location of assignment

The training centre or other venue where supervision and appropriate working conditions will be provided.

2.2 Requirements

Pens, pencils, clipboard and paper

2.3 Instructor notes

Candidates may undertake the work in small groups, provided the report on the system investigated is written up independently. The candidates will need to be able to study the metering installed within the training centre or at a small engineering or commercial premises.

Installation selected must include meters for the following purposes:

Total energy consumed
Maximum demand
kVA
Power factor

2.4 Instructor instructions

A visit to a metering installation must be arranged. This could be within the training centre or at a local commercial or industrial premise, providing the requirements in 2.3 are satisfied.

If a visit to a suitable installation is impractical, a simulated installation may be used.

Health and Safety issues must be explained to candidates in relation to electrical and other hazards which may be present on site.

Writing up the assignment may be done outside the 2 hour practical session.

3 Candidates' instructions

- 3.1 The time allowed for this assignment is 2 hours. You are advised to read all the instructions before commencing the work. If you do not understand all the instructions then please ask your tutor.
- 3.2 A visit will be arranged for you to study a metering installation at a small engineering or commercial premises. You will be required to investigate and record details of the metering arrangement and connections.
You must not touch any part of the wiring during the visit.
- 3.3 Sketch the layout of the metering installation.
- 3.4 Draw a wiring diagram for the installation showing how each meter is connected to the supply.
- 3.5 Explain the function of each meter and why it is necessary.
- 3.6 Explain why a customer may benefit by reducing the maximum demand they make on the supply system and how this could be achieved without reducing the amount of electrical equipment installed.
- 3.7 Explain the benefit to the supplier of reducing maximum demand without reducing overall consumption.
- 3.8 Explain the disadvantages of low power factor both to the supplier and the customer.
- 3.9 Hand in work to the instructor.

4 Marking

- | | | |
|-----|--|-----|
| 4.1 | Assignment completed in 2 hours (excluding write-up). | () |
| 4.2 | Layout of meters sketched correctly. | [] |
| 4.3 | Wiring diagram drawn correctly. | [] |
| 4.4 | Function of each meter stated correctly. | [] |
| 4.6 | Explanation of the benefit to the customer of reducing maximum demand stated correctly. | [] |
| 4.7 | Explanation of the benefit to the supplier if maximum demand is reduced without loss of total consumption. | [] |
| 4.8 | Disadvantages of low power factor explained correctly. | [] |
| 4.9 | Work handed in to the instructor | [] |

5 Assignment completion

The candidate will have satisfactorily completed this assignment if successful in all items marked with a []. It is not essential that the item marked with a () is completed in the time stated.

A period of seven days must elapse before an unsuccessful candidate may retake this assignment.

215 Electrical Practical Assignments

Practical assignments 215/3: Industrial/Commercial Distributions Systems

1 Competence references

214.3

2 Preparation

2.1 Location of tests

The training centre or other venue where supervision and appropriate working conditions will be provided.

2.2 Requirements

Pens, pencils, clipboard and paper.

2.3 Instructor notes

Candidates may undertake the work in small groups, provided the report on the system investigated is written up independently.

The candidates will need to be able to study the distribution system within the training centre or at a small engineering or commercial premises.

2.4 Instructor instructions

A visit to the substation within or supplying the training centre or alternatively a small engineering / commercial premises must be arranged. The candidates will need to be able to trace the main circuits supplied from the substation. If necessary, this could be done from drawings of the system if access is difficult.

Detailed wiring diagrams are not required.

Health and Safety issues must be explained to candidates in relation to the electrical hazards present in substations and other hazards present in industrial / commercial premises.

Writing up this assignment may be done outside the 2 hour practical session.

3 Candidates' instructions

- 3.1 The time allowed for this assignment is 2 hours (excluding the write up). You are advised to read all the instructions before commencing work. If you do not understand the instructions, then please ask your instructor.
- 3.2 A visit will be arranged for you to study a small distribution system. You will be required to investigate and record the basic arrangement of the system and the types of equipment used.
 - 3.2.1 Sketch the layout of the local substation
 - 3.2.2 Record the type of switchgear installed and its rating
 - 3.2.3 Record the type of protection used for the circuits
 - 3.2.4 Record other equipment installed.
 - 3.2.5 Draw single line and block diagram showing the equipment installed between the substation and the outlets for power, lighting and electrical machinery. **It is not necessary to produce detailed wiring diagrams for the system.**
 - 3.2.6 Describe the purpose of each piece of equipment included in 3.2.1 – 3.2.5 above.
 - 3.2.7 State the types of protection used for each part of the system.
 - 3.2.8 For each section of the system explain what will happen in the event of a fault arising within that section.
- 3.3 Put your name on your work and hand it in to the instructor.

4 Marking

- 4.1 Assignment completed in 2 hours (excluding write up). ()
- 4.2.1 Layout of the substation sketched correctly. []
- 4.2.2 Switchgear type and rating stated correctly. []
- 4.2.3 Type of protection stated correctly. ()
- 4.2.4 Other substation equipment identified correctly. ()
- 4.2.5 Line and block diagram of the distribution system is a fair representation of the system. []
- 4.2.6 Function of the main components of the system described correctly. []
- 4.2.7 Basic protection installed for each part of the system stated correctly. []
- 4.2.8 Operation of protection for faults arising on the system described correctly. []
- 4.3 Work handed in. []

5 Assignment completion

The candidate will have satisfactorily completed this assignment if successful in all items marked with a [] and at least 1 of the items marked with a ().

A period of seven days must elapse before an unsuccessful candidate may retake this assignment.

Appendix A

Practical assignments

Two assessment methods are used in the 8030 (2000) Technician Awards in Engineering programme – written questions and practical assignments.

Practical assignments

Some of the units or components in the Diploma level of this programme have a related practical assignment or assignments. These assignments may call on skills covered in other sections but reference is only made to the competences covered by the marking criteria. Wherever relevant the option is given for you to use local names, local currencies, alternative measurements and paper sizes, or to design an alternative assessment. Where this option is taken **the assignment must be of a comparable standard** to ensure consistency between centres using this programme. The assignment must be documented and available for the visiting verifier. ALL assignments must be successfully completed.

The assignments may be administered at any time convenient to the instructor and to the candidate.

The practical assignments in this publication are intended to be photocopied.

Instructor notes

It is essential that you read these before attempting to administer the practical assignment. Practical assignments usually require you to prepare material for the assignment.

Candidate instructions

Make sure every candidate has a copy of these before beginning the practical assignment.

Marking

The marking is based on performance criteria or outcomes related to the practical assignment, to which the answer will always be either 'yes – the candidate achieved this' or 'no – the candidate did not achieve this'. Credit is given for those performance objectives for which the answer is 'yes – the candidate achieved this'.

Supervision

All assignments require supervision and you must make sure that the results reflect only the individual candidate's own work. You must keep all assessment documentation and material in a file for each candidate until the results have been agreed by the visiting verifier and until confirmation of result has been received from City & Guilds.

Records, results and certification

Successful completion of the related practical assignments for each unit needs to be recorded and then sent to City & Guilds. We suggest that you keep a record of each individual's achievements which may then be transferred to the entry forms. A model is given at the end of this section but you may use any form of record keeping that is convenient and accessible.

In order to gain certification, results for successfully completed practical assignments must be sent to City & Guilds. Results for practical assignments are entered onto Form S which is then countersigned by the visiting verifier and sent to us.

An advantage of this programme is that candidates who successfully complete the practical assignments for a single unit may, if they wish, claim a Certificate of Unit Credit. This may be beneficial for those candidates who only wish to complete part of this programme. Send these claims to us at any time provided the visiting verifier has countersigned the Form S.

Candidates wishing to gain the full award (Certificate, Diploma or Advanced Diploma) must successfully complete all the relevant practical assignments. We recommend that their practical results are sent at the time of, or shortly before the date of the written examinations.

Visiting verifier

The operation of this programme requires the appointment of a visiting verifier. **The visiting verifier must countersign the results of the practical assignments on Form S.** The visiting verifier should also be able to inspect records and candidates' work to verify the results before submission.

Technician Diploma in Applied Electronic Engineering Candidate assessment record

Candidates must complete these assignments

Candidate's name and number

Centre name and number

Assessment reference	Date completed	Instructor signature	Instructor name
211/1 Engineering Database			
211/2 Engineering Spreadsheet			
211/3 Word processing – a business letter			
213/1 Wave shaping			
213/2 Common emitter transistor amplifier			
213/3 Integrated circuit power amplifier			

Technician Diploma in Applied Electronic Engineering Candidate assessment record

Candidates must complete these assignments

Candidate's name and number

Centre name and number

Assessment reference	Date completed	Instructor signature	Instructor name
211/1 Engineering Database			
211/2 Engineering Spreadsheet			
211/3 Word processing – a business letter			
215/1 Earth electrode tests			
215/2 Metering Installations			
215/3 Industrial commercial distribution systems			

[This page is intentionally blank]

Published by City & Guilds
1 Giltspur Street
London
EC1A 9DD
T +44 (0)20 7294 2850
F +44 (0)20 7294 2413
intops@cityandguilds.com
www.cityandguilds.com

City & Guilds is a registered
charity established to promote
education and training